

North Creek

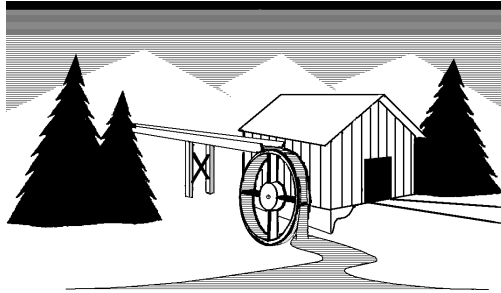

Music Systems

Echo-T

**MTM Mini-Tower
Loudspeaker System**

**A small tower loudspeaker featuring the
North D25-06S and dual North 13W-06S 's
in an acoustic suspension tower.**

Woodworker's Kit Contents:

The woodworker's kit portion of this loudspeaker system was shipped in one carton.

This carton contains:

- (1) Instruction package.
 - Cabinet Assembly Manual
 - Response Curves
 - North Creek *Cabinet Handbook*
 - North Creek Wiring Guide

- (4) 1 oz. Rolls of Dacron stuffing.
- (1) Tube of "Liquid Nails" adhesive.

- (2) Rolls of gasket tape.
- (16) Mushroom grille fasteners.
- (24) #6 - 1" black screws.
- (16) 1 5/8" black drywall screws
- (8) 2 1/2" steel deck screws
- (2) single wired back cups with extra gold plated nuts and post pins
- (1) Set of Big Toe Spikes
- (1) Set of Very Big Toe Spikes
- (2) Plastic Sand Bags with twisties

- (1) Bag of Woofer Crossover Parts.
- (1) Bag of Tweeter Crossover Parts

- (2) North D25-06S tweeters.
- (4) North 13W-06S woofers

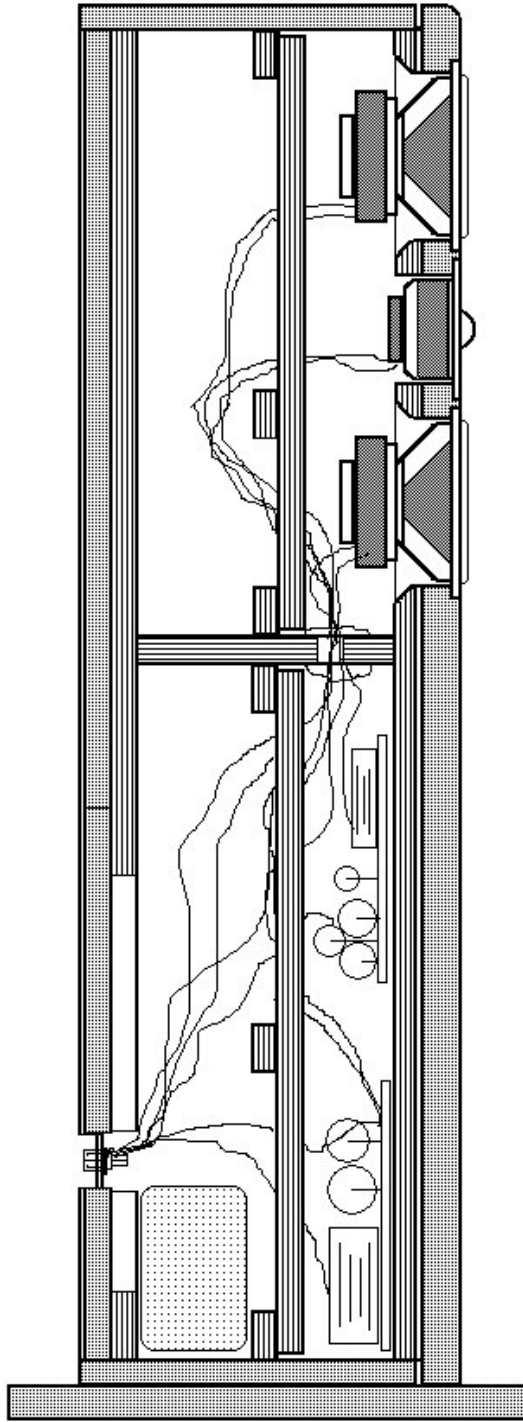

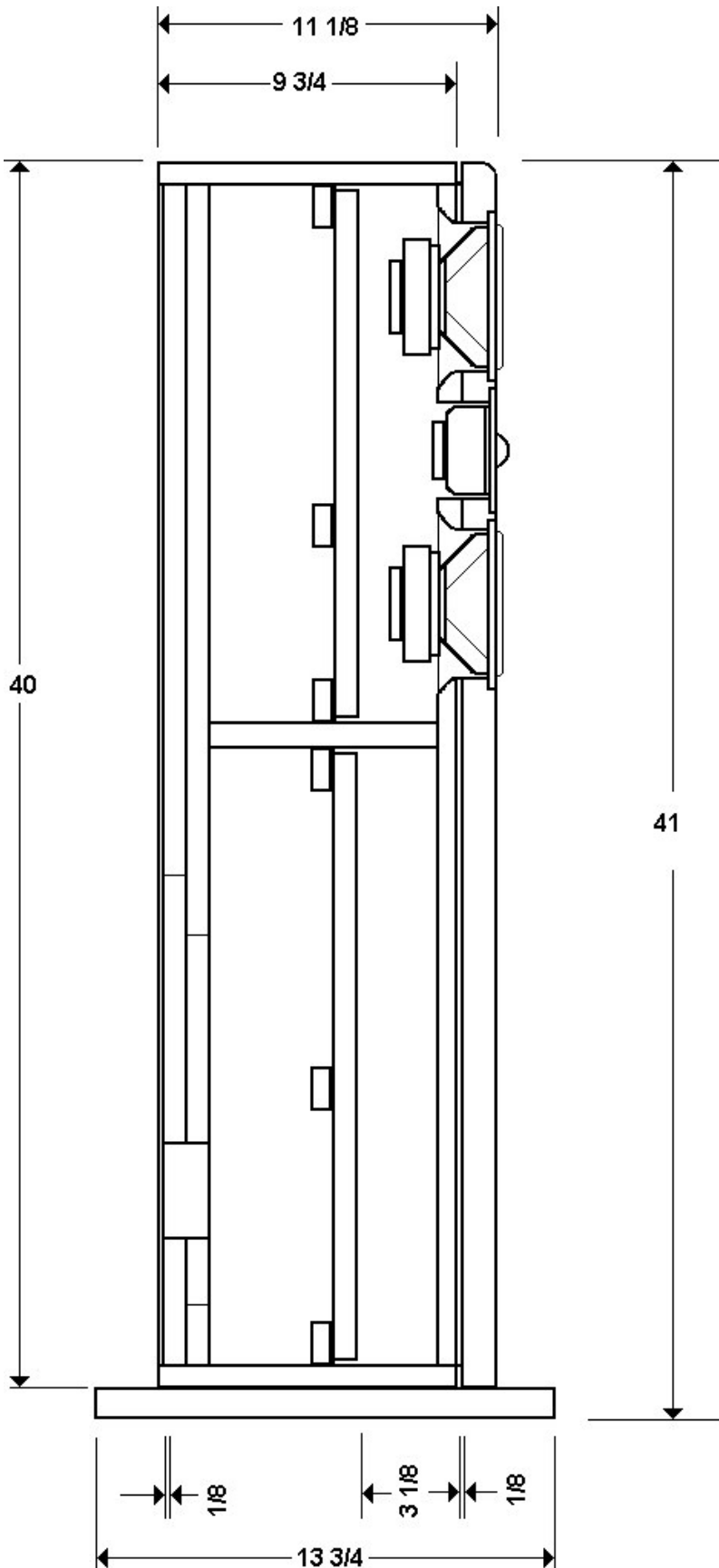

An overall dimensioned side view. Note that the back panel is inset $\frac{1}{8}$ ", whilst the fascia is outset $\frac{1}{8}$ ". This is purely cosmetic; one may eliminate both without affecting the internal box dimensions.

Additionally, the fascia is $1 \frac{1}{4}$ " MDF. This was made with one layer of $\frac{3}{4}$ " and one layer of $\frac{1}{2}$ " MDF, glued together with Titebond. One may use two layers of $\frac{3}{4}$ " if this is more convenient, as this is also cosmetic and will not affect the system performance.

Side Panels: four pieces;
3/4" MDF, 9 3/4" x 40"

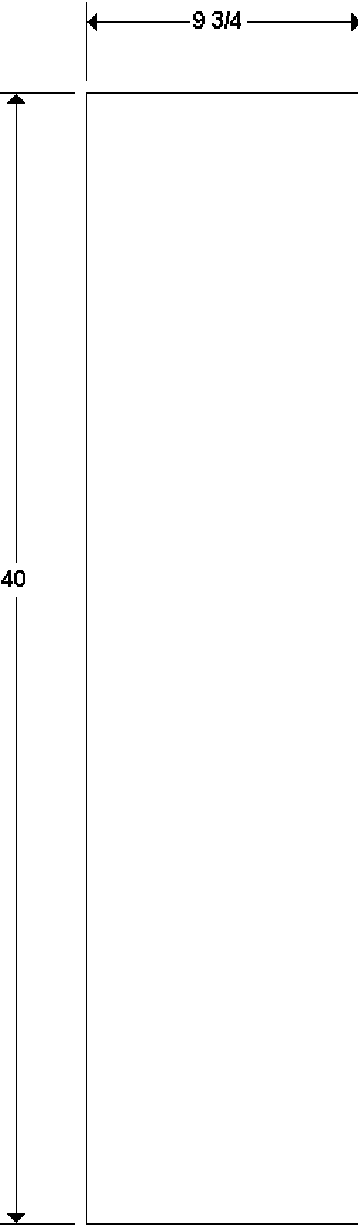
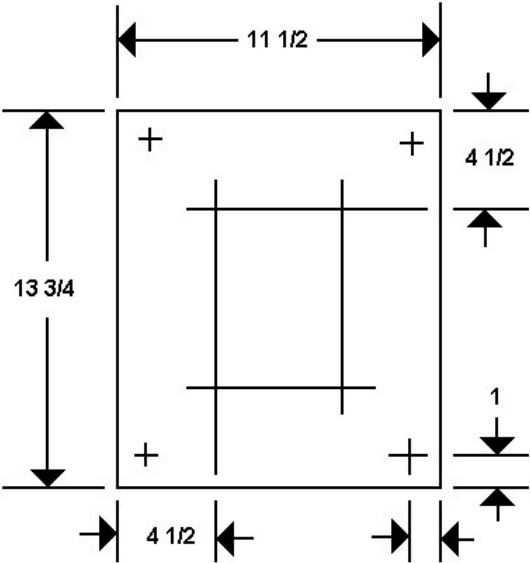

Plinth
2 pieces, 1" MDF, 11 1/2 x 13 3/4
Spike holes are 1/2" diameter

Top and Bottom panels:
4 pieces, 3/4" MDF, 9 3/4" x 6"

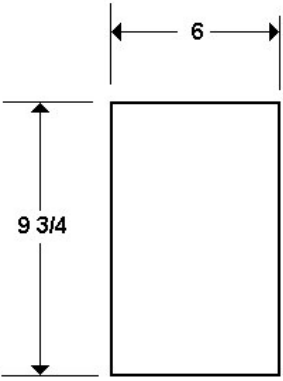

Inner Back, Inner Front Panels:

4 pieces 3/4" Birch Plywood
6 x 38 1/2

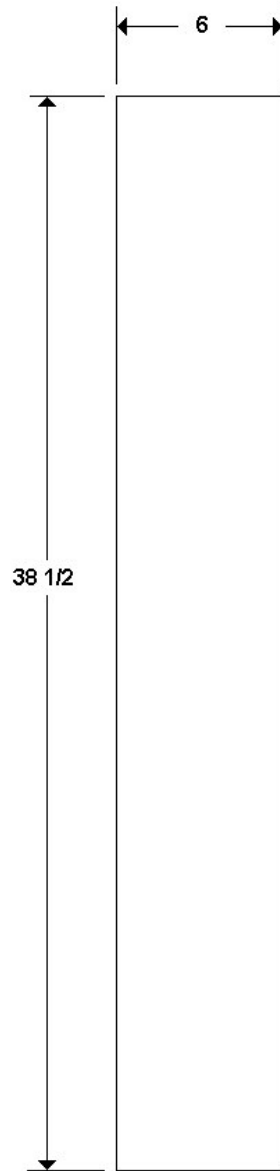

Fascia:
2 piece 1 1/4" or 1 1/2" MDF
(may be a lamination);
7 1/2 x 40

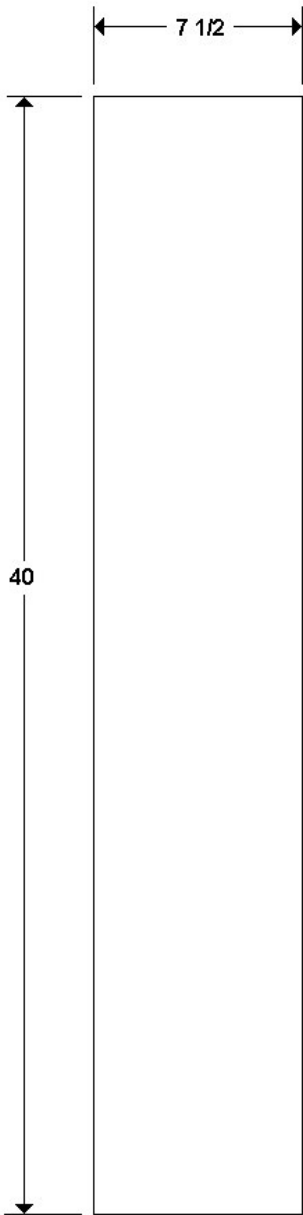

Outside Upper Back
3/4" MDF
2 pieces 6 x 22 1/2

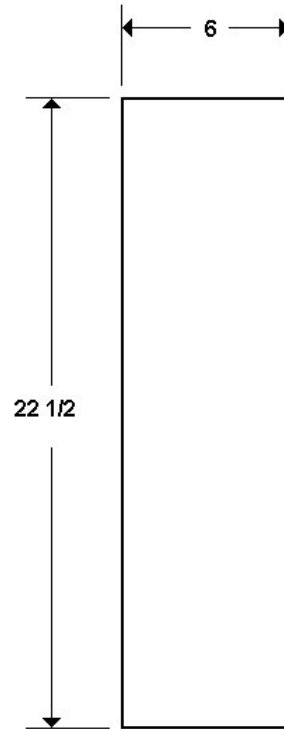

Outside Lower Back
2 pieces MDF
6 7/8 x 15 7/8

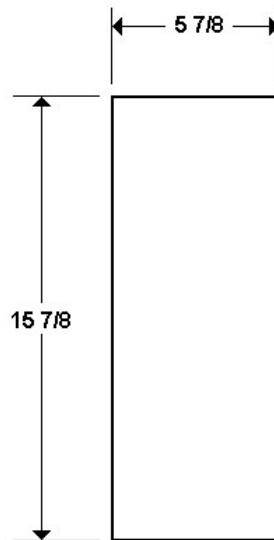

Braces:

3/4" birch plywood,
4 pieces 1 1/4" x 17"
12 pieces 1 1/4" x 5 1/2"
4 pieces 1 1/4" x 19 1/2"

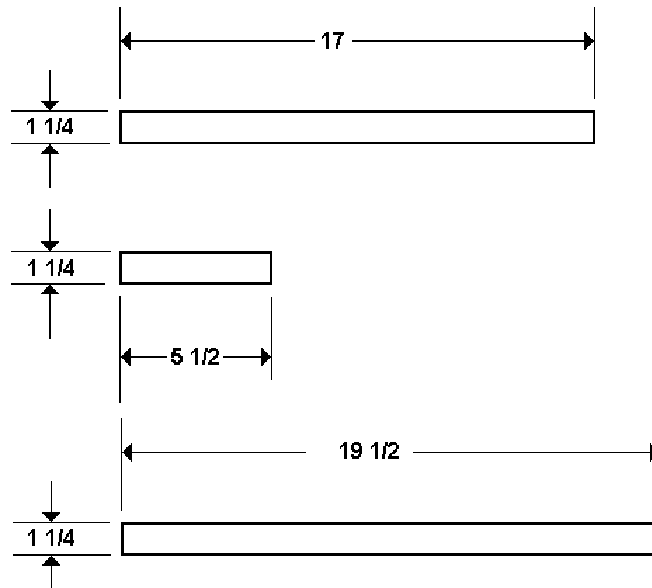

Horizontal Shelf Brace
3/4" plywood
2 pieces 6 x 7 1/2"

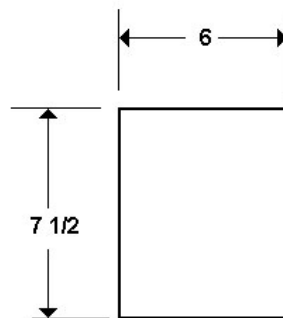

Back Panel Detail:

This panel is composed of birch plywood, laminated to the MDF Upper Back with hard glue such as Titebond.

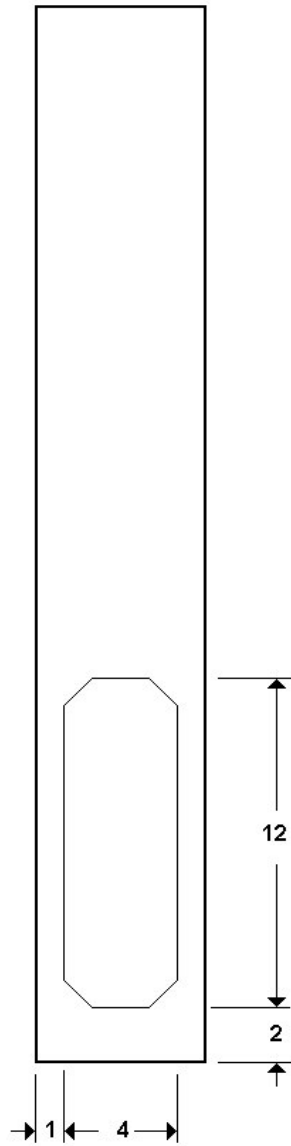

Outside Lower Back Detail

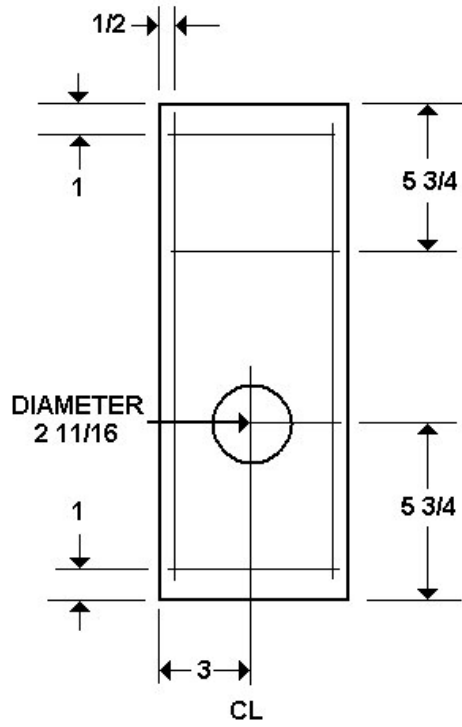

Shelf Brace Detail

Wire through-hole is 3/4" diameter

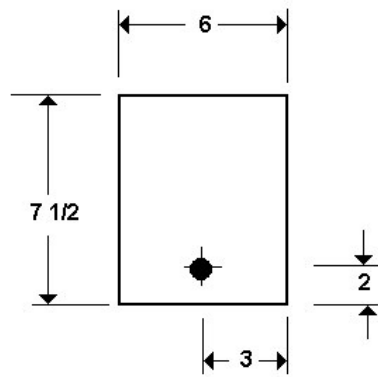

Inner Front Detail:

This panel is machined from 3/4" birch plywood.

After machining, the inside edge of the woofer cut out should be flared by a 1/4" radius to 1/2" radius roundover bit (the larger the diameter of this roundover, the better). The roundover should then be sanded smooth.

Both the woofer and tweeter through holes should be sealed with a very thin layer of hard glue, to prevent any air leak due to the porosity of the plywood.

Note that the through hole for both the woofer and tweeter are the same diameter as the matching openings in the Fascia. All of these panels should be machined with the same setting on a router circle cutter.

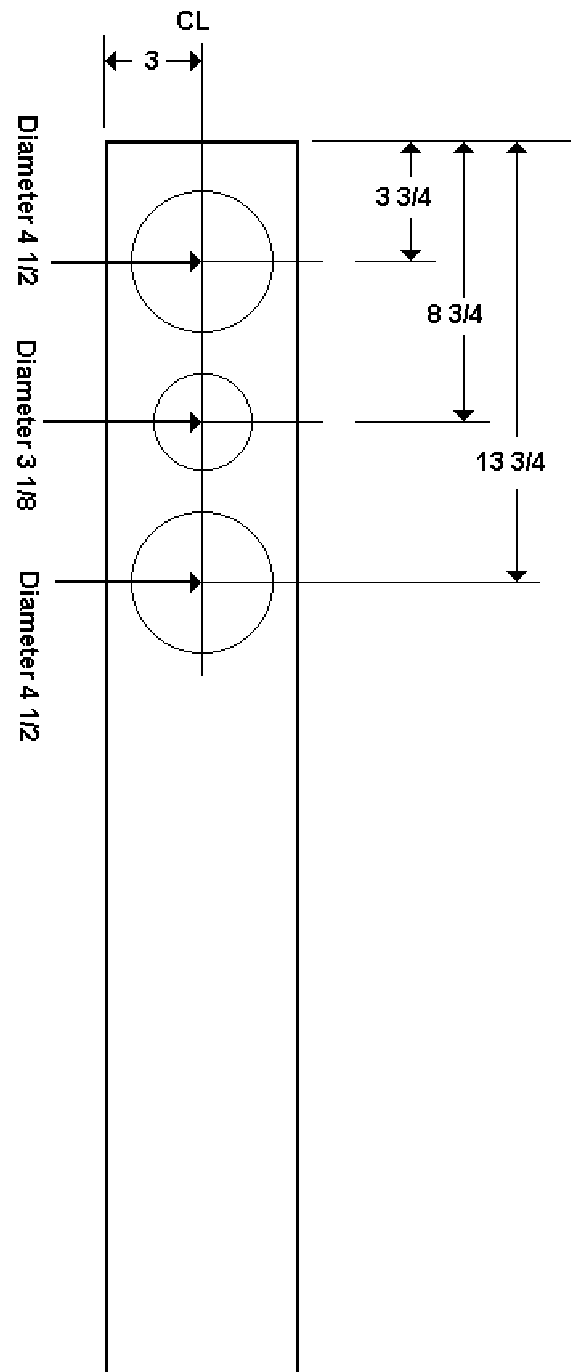

Fascia Detail:

This panel may be either 1 1/4" MDF or 1 1/2" MDF. It may be constructed of a single layer, two layers of 3/4" material, or a layer of 3/4" and a layer of 1/2". If using two layers, the adhesive should be a hard glue such as Titebond.

When machining the woofer and tweeter countersinks, measure carefully to be absolutely certain they are the correct diameter. The diameter we specify is actually very slightly larger than the flange driver flange diameters, to account for the thickness of any paint or surface finish.

Woofer and tweeter mounting holes should be drilled at this point.

The front edge of the fascia is rounded over with a minimum 3/8" radius, maximum 5/8" radius roundover bit. If one chooses to veneer the front, roundover the side edges and leave the top and bottom square.

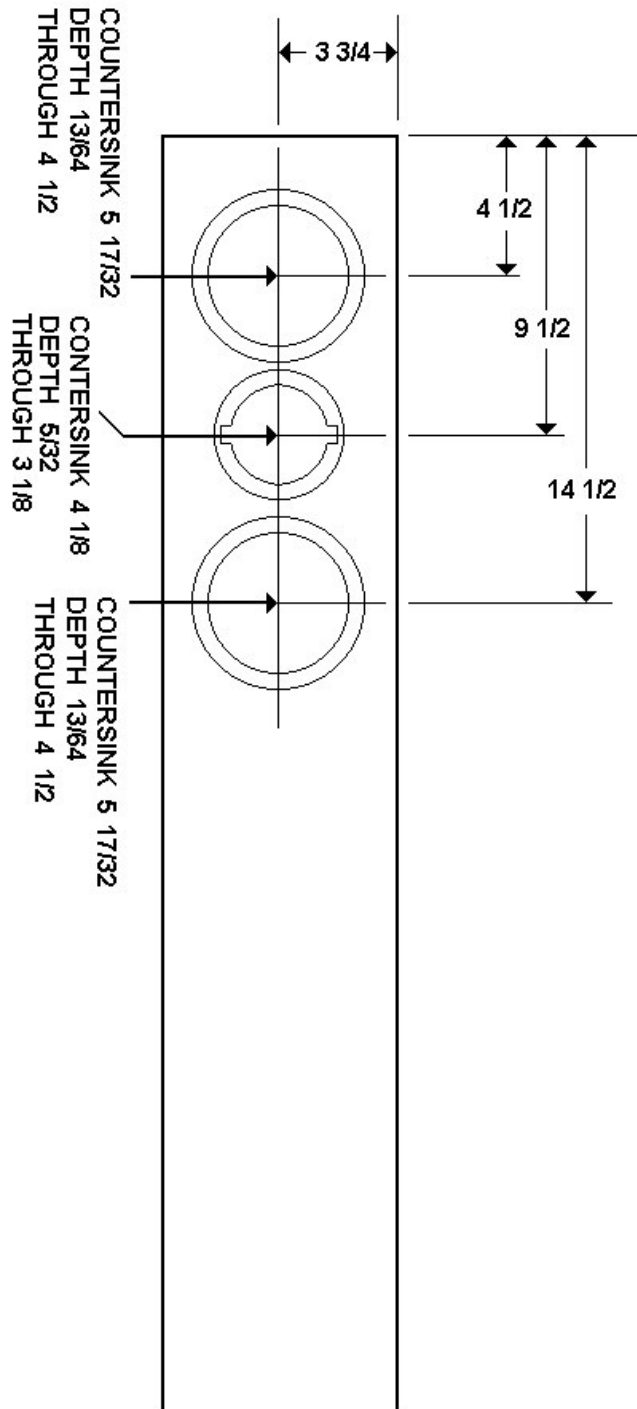

Assembly order:

Brace on sides;
Lay up inner back and upper
back;

Side + top + back; inner
front;

Trim the shelf brace for a
perfect fit, glue and tap into
place;

side, bottom, cross-braces.
It is easiest to attach the
cross-braces with pinch
clamps.

It is assumed the Fascia is
finished separately and
attached last.

The plinth is attached with
screws last.

Note the brace is offset $3\frac{1}{8}$ " from the front edge of
the top and side
panels. This is $3\frac{1}{4}$ " from
the projecting edge of the
"inner front".

Note that the back panel is
inset $\frac{1}{8}$ ", whilst the fascia is
outset $\frac{1}{8}$ ". This is purely
cosmetic; one may eliminate
both without affecting the
internal box dimensions.

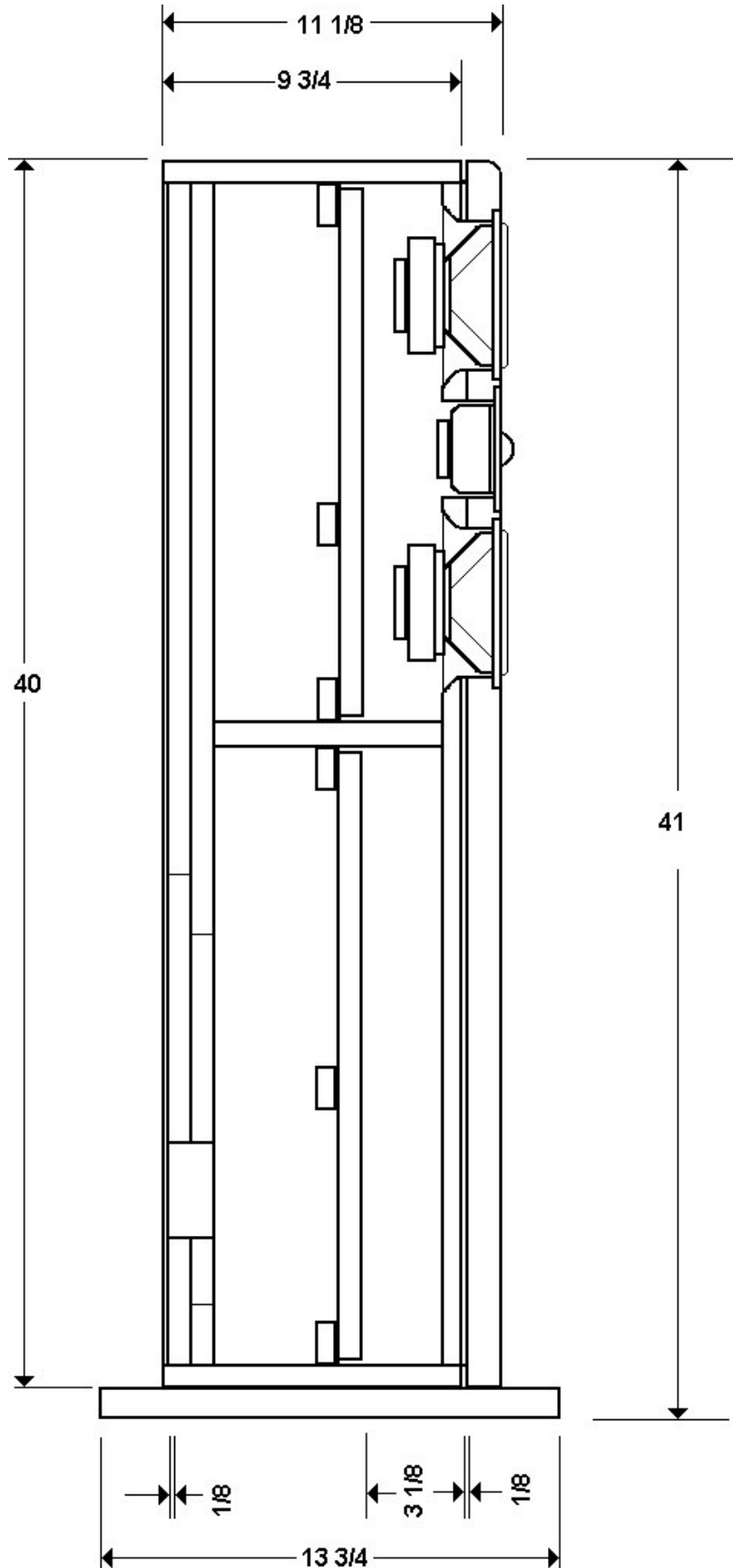

Crossover and Driver installation:

1) With the cabinet on its front, inside the lower chamber, apply several large beads of Liquid Nails adhesive to the plywood inner front. Install the woofer and tweeter networks, being careful not to trap any wires beneath them. Let this dry overnight.

2) Run the driver wiring through the hole in the shelf brace.

3) Install the binding post cup in the rear cover and the crossover leads to the binding posts as follows:

Red coil lead and White tweeter crossover lead to red post;
Black and Blue Crossover leads to black post;

Line the inner back cut out with gasket tape and attach the outer lower back with 1 5/8" black drywall screws.

4) The cabinet is then placed on its back, the woofer and tweeter wires pulled through the shelf brace and wrapped around the middle cross brace. Seal the hole in the shelf brace with liquid nails or silicone.

5) Push half of the stuffing behind each woofer. Be careful not to cover the end of the port tube with stuffing.

6) Adhere gasket tape to the woofer and tweeter countersinks, starting at the tip right screw hole, and trim off excess. Puncture through the gasket tape to mark the mounting screw positions.

7) The white (+) and blue (-) leads are attached to the tweeter, red (+) from the crossover board and black (-) from the jumper to one woofer, and the black (-)

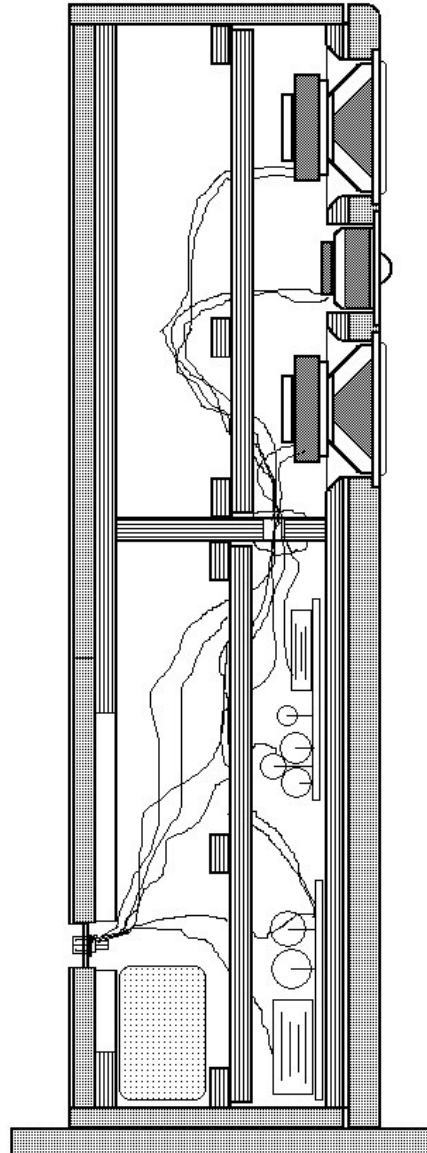

from the crossover board and red (+) to the other woofer. All drivers are mounted with #6 screws.

8) Once final placement is determined, the sand bag is installed in the lower chamber and the spikes on the plinth.

North Creek Music Systems

PO Box 1120
Old Forge NY 13420

www.NorthCreekMusic.com