

**North Creek**

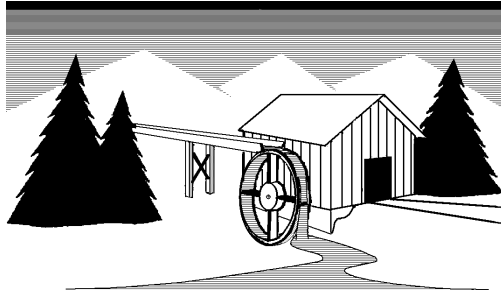

**Music Systems**

# **Echo-1**

**Crossover Assembly Manual**

**A mini-tower loudspeaker featuring  
Dual North 13W-06S and North D25-06S  
in an acoustic suspension cabinet.**



## **Required Tools:**

These are the basic tools required to complete this project. The items listed below are all available from MCM Electronics, [www.mcmonline.com](http://www.mcmonline.com), 800-453-4330. The tools suggested are the least costly that will do the job. There are certainly better quality tools out there for considerably more money. The brands that seem to be the best are Xcelite, Ideal and Klein. MCM also carries all of these brands.

Always solder in a well ventilated area.

Tool:	MCM Part Number	MCM \$
Wire Cutter/Stripper	22-1635	\$ 4.99
Crimper	22-1780	10.05 (#22-1795 by Klein is better, twice the price)
Soldering Iron (80 Watt)	21-4345	8.23
Soldering Iron Holder	21-3525	1.49
Heat Gun	21-7315	17.95

3/8" nut driver or flat head screw driver

colored nail polish

## **Wire Prep:**

Cut the wire to the appropriate length, strip 1/2" from all ends, and either leave bare or attach, crimp and solder the appropriate connection as indicated by the table below.

Quantity	Material	Length	one end	other end
2	black Tef-Flex	16"	1/2" bare	1/2" bare
2	black Lex	5 feet	1/2" bare	0.110" quick connect
2	red Lex	16"	0.110" quick	0.110" quick connect (series jumper)
2	red Lex	5 feet	1/2" bare	0.110" quick connect
2	blue Tef	5 feet	1/2" bare	0.250" quick connect
4	blue Tef	16"	1/2" bare	1/2" bare
2	white Tef	16"	1/2" bare	gold Big Ring Jr.
2	white Tef	5 feet	1/2" bare	0.250" quick connect
2	4.4mH inductor	long	1/2" bare	gold Big Ring Jr on long inner lead
2	0.56mH inductor	5" both	1/2" bare	1/2" bare
2	buss bar	4"	all bare	<i>the easy way to strip the buss bar is to slice off the insulation with a drywall knife</i>

## Jumper Prep:

For the series jumpers, shrink tube one end red and one end black.

## Resistor Prep:

With the label up, bend both leads straight down, then bend 1/4" of each end straight out (into an "L"). This method allows the legs to function both as the connectors and as the means of suspending the resistor above the board.

Please read the *North Creek Wiring Guide*, included with the kit package

## Woofer Network Assembly

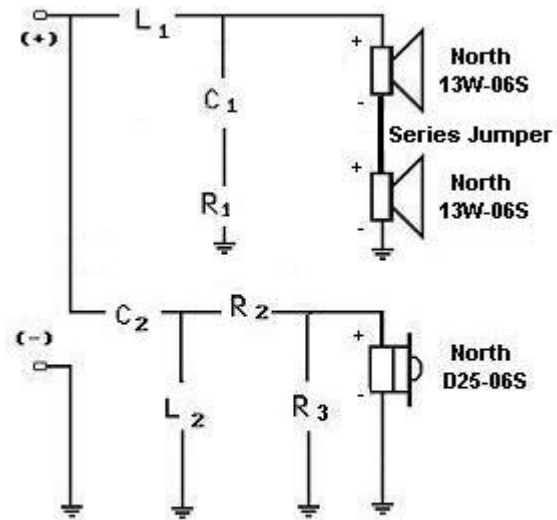

North Creek Echo-T and Echo-C Crossover

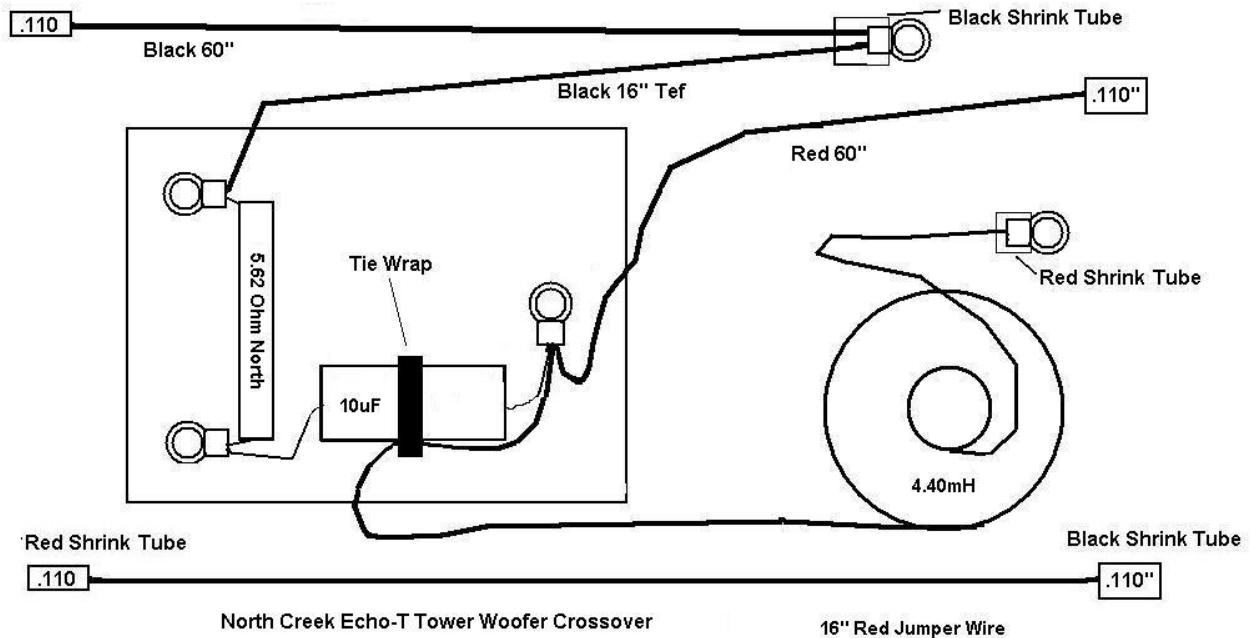

Closely inspect our crossover assembly diagram. This is built on a 3x4 board.

**"Attach" means "slide all leads into a single ring tongue crimping section, crimp, and solder**

Attach the 16" black Tef-Flex wire to one lead of the 5.62 Ohm resistor.

Attach the other end of the 5.62 Ohm resistor and one end of the 10uF Yellow cap.

Attach the two remaining lead of the 10uF, the outside lead from the 4.40mH inductor, and the 60" red woofer lead in a single ring tongue.

Attach the 16" black Tef wire and the stripped end of the 60" black Lex wire with a single gold Big Ring Jr.

When everything cools down, drop three brass screws through the rear of the pegboard as indicated on the assembled crossover diagram. Flip the board over and drop the ring sections over the screws, attach with the nuts, tighten, and drop nail polish on the exposed threads.

Shoot a little silicone under the capacitor and bind it and the inductor lead to the pegboard with a single tie wrap as shown on our diagram. **It is very important that the inductor lead is secured under the tie wrap and in the silicone.**

Shrink black shrink tube over the crimped section of the gold Big Ring Jr that holds the two black wires.

Shrink red shrink tube over the crimped section if the gold big Ring Jr that is attached to the 4.40mH inductor.

Carefully inspect the assembly to make sure everything is exactly as our assembled crossover diagram.

## Tweeter Network Assembly

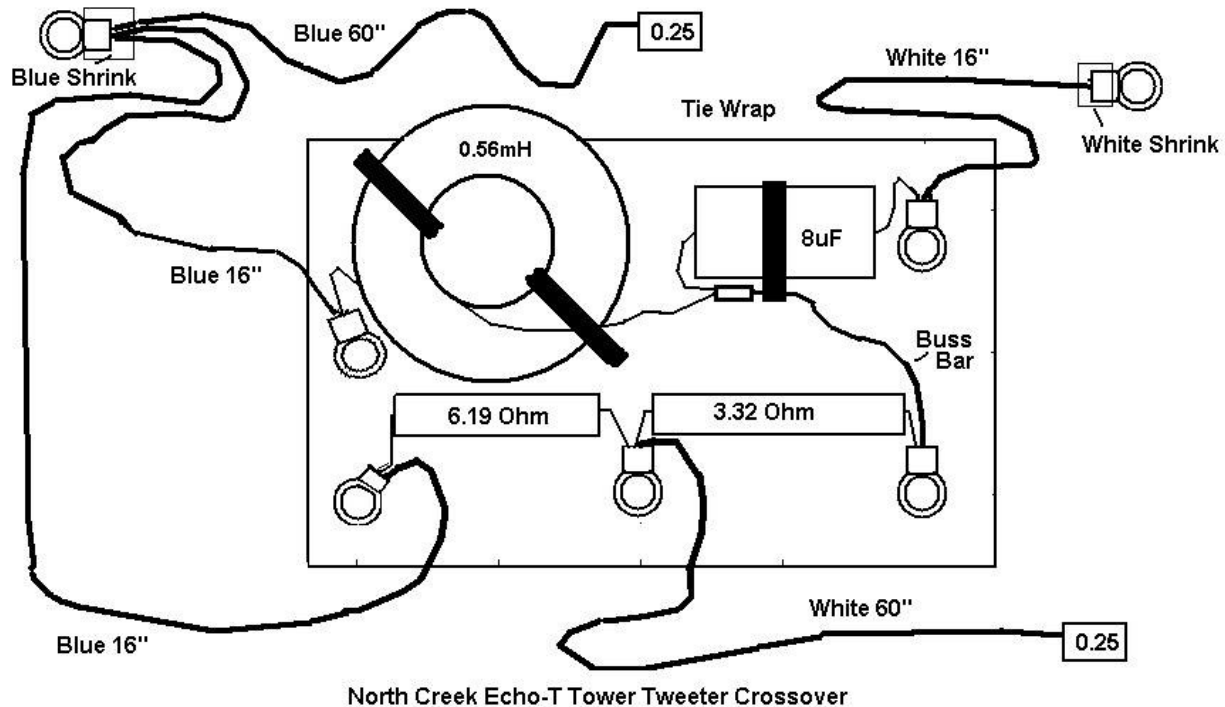

Carefully inspect our assembled network diagram. This is a 4x5 board.

**"Attach" means "slide all leads into a single ring tongue crimping section, crimp, and solder**

Attach the stripped end of the 16" white wire to the gray leads of the 8uF Yellow cap with a single ring tongue

Attach one 16" blue wire to the outside lead of the 0.56mH inductor

Attach one 16" blue wire to one lead of one of the 6.19 Ohm resistor

Attach the stripped 3" buss bar to one lead of the other 3.32 Ohm resistor

Attach the free leads of both resistors and the 60" white Tef wire with a single ring tongue.

When everything cools down, attach the resistor sub-assembly to the peg board and tighten down the brass nuts to hold everything in place.

Attach the capacitor sub-assembly to the pegboard as indicated on our crossover diagram.

Attach the free end of the buss bar, the free end of the 0.56mH inductor, and the free lead from the 8uF Yellow cap with a single large crimp barrel.

When everything cools down, shoot a little silicone under the capacitor and secure it and the buss bar/capacitor/inductor connection point with a long tie wrap. Make sure the buss bar is not touching any other connection, and coat it with silicone.

Drop the inductor into place on the pegboard, loosely secure with tie wraps, add a little silicone under the inductor, tighten the tie wraps, trim excess

Attach the inductor-blue wire ring tongue to the pegboard

Attach the stripped ends of both 16" blue leads and the 60" blue lead with a single gold Big Ring Jr.

Heat shrink white shrink tube over the crimp section of the Big Ring Jr attached to the 16" white lead.

Heat shrink blue shrink tube over the crimp section of the Big Ring Jr attached to the three blue wires.

Carefully inspect the assembly to make sure everything is exactly as our assembled crossover diagram.

### Installation:

The white (+) and blue (-) leads are attached to the tweeter, red (+) from the crossover board and black (-) from the jumper to one woofer, and the black (-) from the crossover board and red (+) to the other woofer. All drivers are mounted with #6 screws.

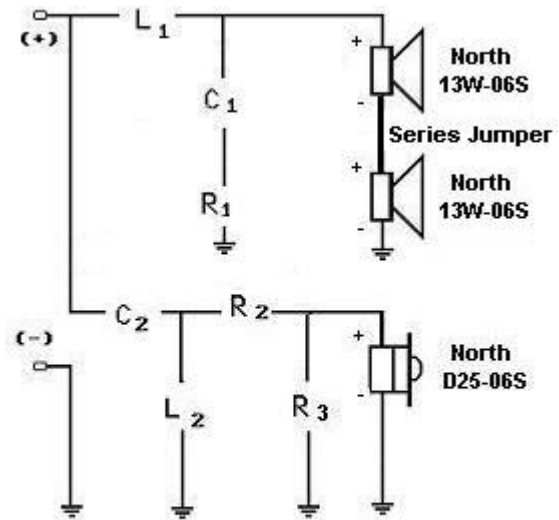

North Creek Echo-T and Echo-C Crossover

**North Creek Music Systems**

PO Box 1120  
Old Forge NY 13420

[www.NorthCreekMusic.com](http://www.NorthCreekMusic.com)