

North Creek

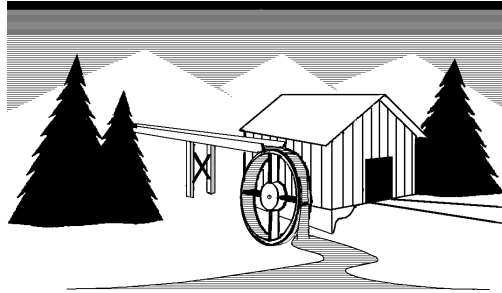

Music Systems

KITTY-KAT REVELATOR
Loudspeaker Cabinet

Near-Wall Specific Monitor Loudspeaker
featuring the
SCAN-SPEAK 15W Revelator Woofer
and NORTH D28A Aluminum Dome Tweeter
in a QB3 Vented Cabinet.

NORTH KITTY KAT

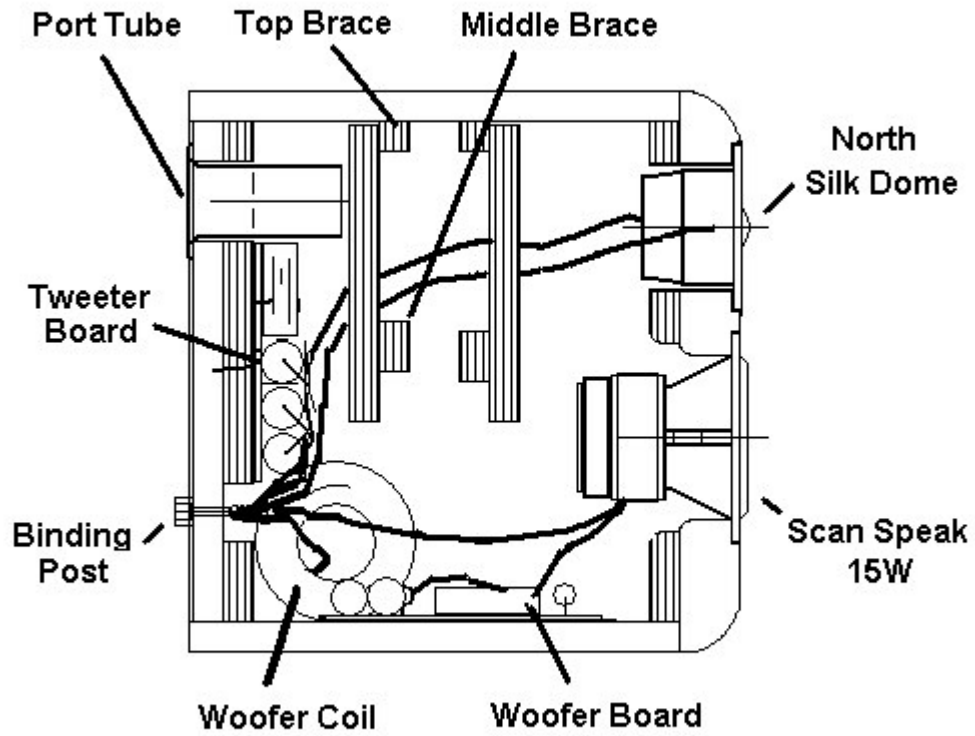

This carton contains:

- (1) Instruction package.
Response Curves
North Creek *Cabinet Handbook*
North Creek Wiring Guide

- (1) 6 oz. Roll of Dacron stuffing.
- (1) Tube of "Liquid Nails" adhesive.
- (1) 8 ounces of NCMS Soft Glue (1/4 of a liter bottle).

- (2) 2" x 3" flared port tubes
- (140) Black Straws
- (8) Mushroom grille fasteners.
- (20) #6- 1" black screws.
- (1) Set of 4 North Creek Big as Texas Binding Posts
- (4) extra gold plated Texas Post Nuts

- (2) Assembled woofer crossover networks.
- (2) Assembled tweeter crossover networks.

- (2) North D28-06A Tweeters.
- (2) Shielded Scan Speak 15W4351G00SC Woofers.

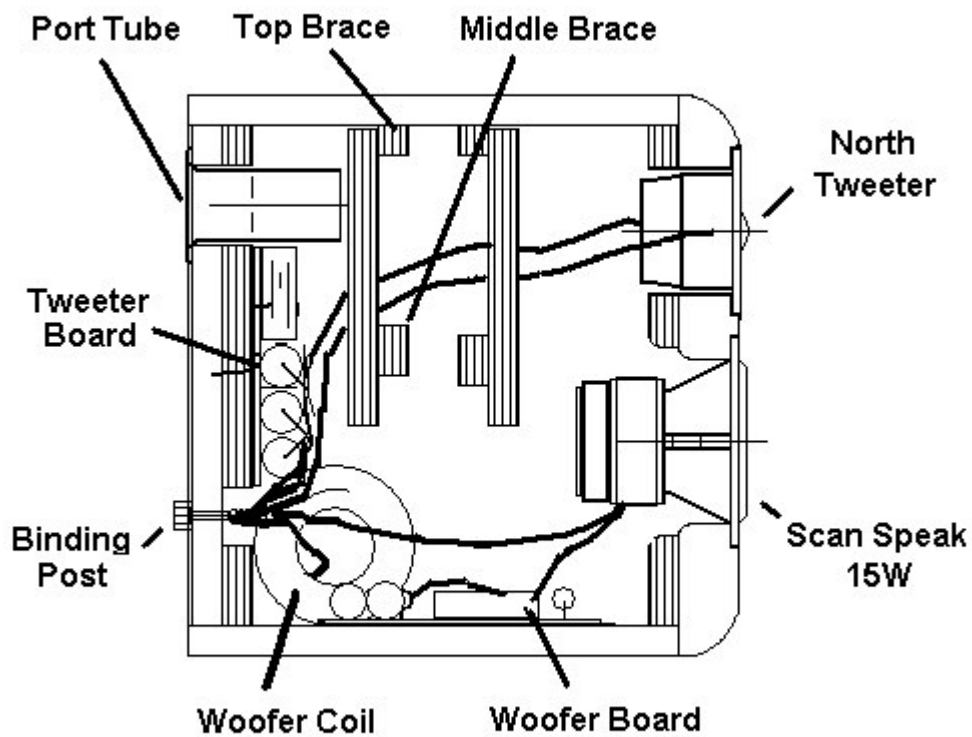

An

overall dimensioned side view.

The fascia is 1 1/2" MDF. This can be made from two layers of 3/4" MDF glued together with Titebond.

Top and bottom panels:
four pieces; 3/4" MDF, 7" x 12.25"

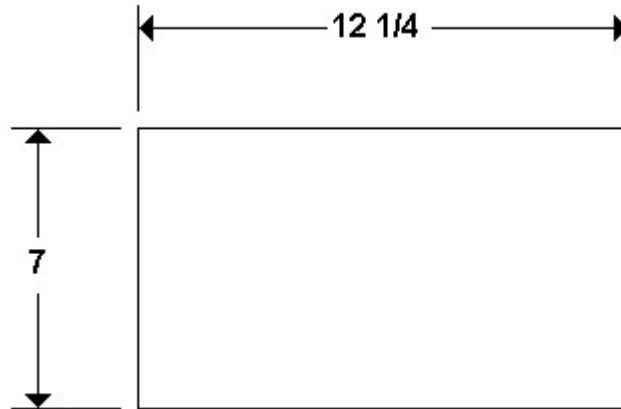

Side panels: 4 pieces, 3/4" MDF, 12.25" x 14"

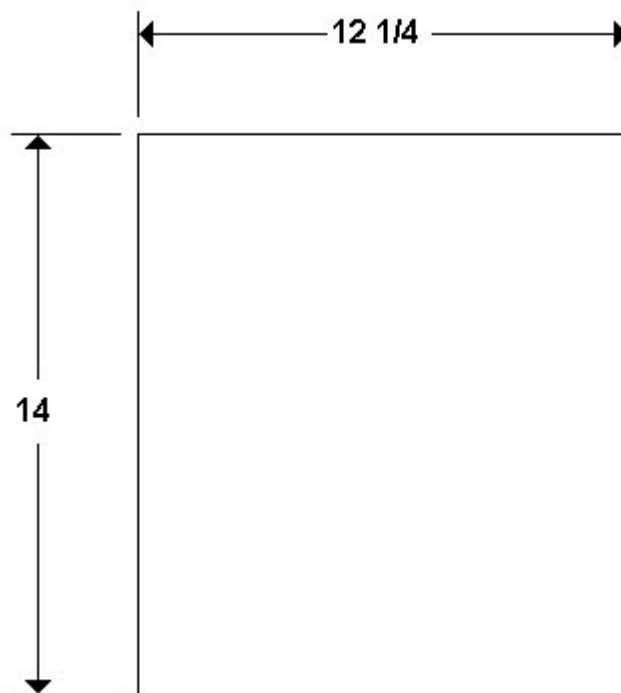

Inner and Outer Back, Inner Front:
2 pieces 3/4" MDF,
4 pieces 3/4" plywood, 7 x 12.5

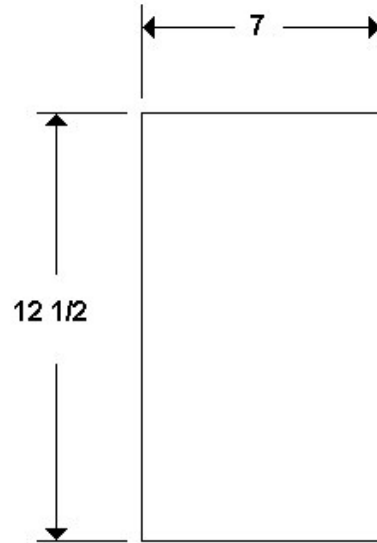

Fascia: 2 pieces 1 1/4" or 1 1/2" MDF
(may be a Titebond lamination of 2 x 3/4" MDF)
8.5" x 14"

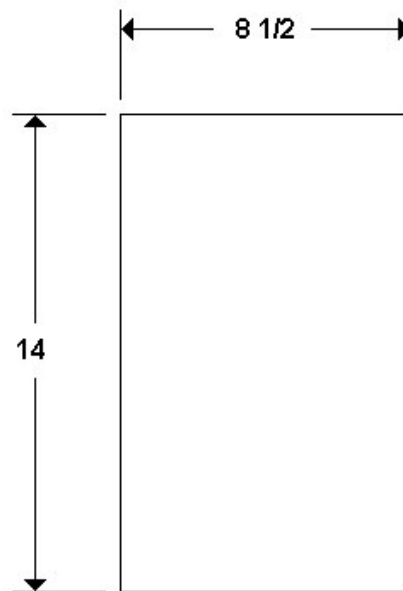

Braces:

- 4 pieces 3/4" Plywood 3/4" x 7.5"
- 4 pieces 3/4" Plywood 1 1/4" x 7.5"
- 8 pieces 3/4" Plywood 1 1/4" x 6"

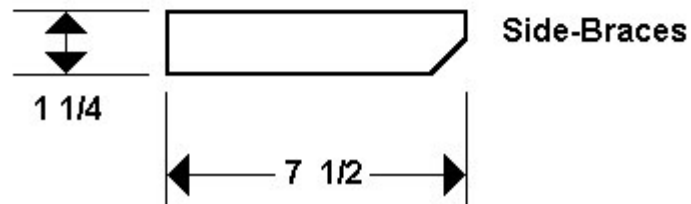
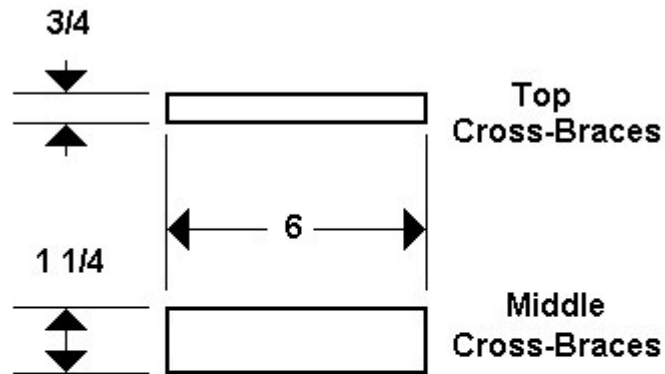

Outer Back Panel Detail:

This panel is composed of one layer of MDF and one layer of plywood, laminated with NCMS soft glue. The MDF layer is on the outside.

This is the outer back detail. The 2" diameter port tube cut out is drilled through both panels and should line up well, but there is a little play, and one can drill the hole in the plywood inner back panel slightly larger if need be.

The two binding post holes are 1/4" to 9/32", spaced 1" apart.

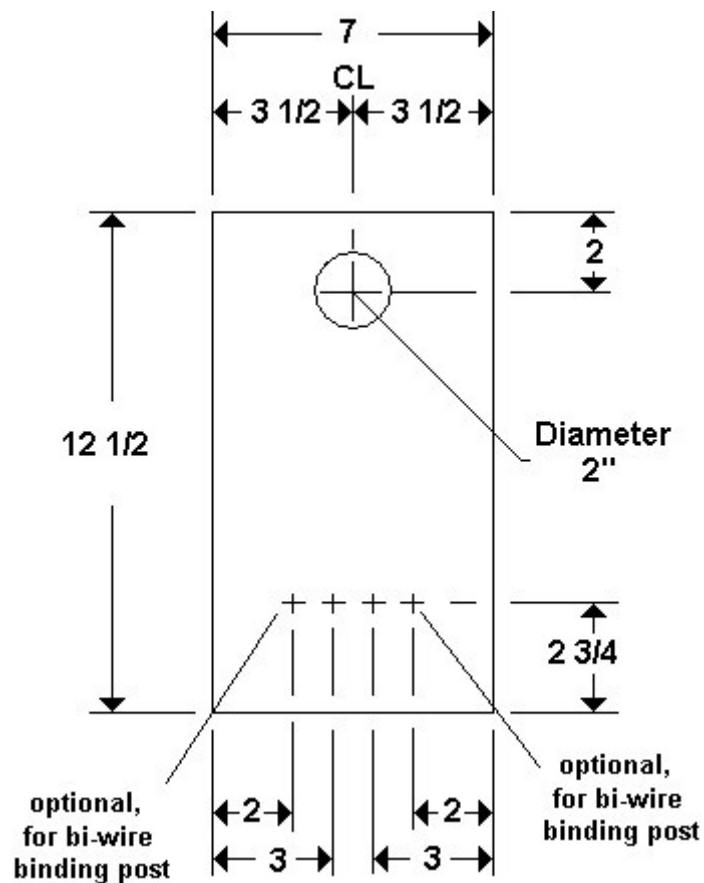

Inner Back Panel Detail:

This is the inner back detail.

Note the cut out area around the binding post positions.

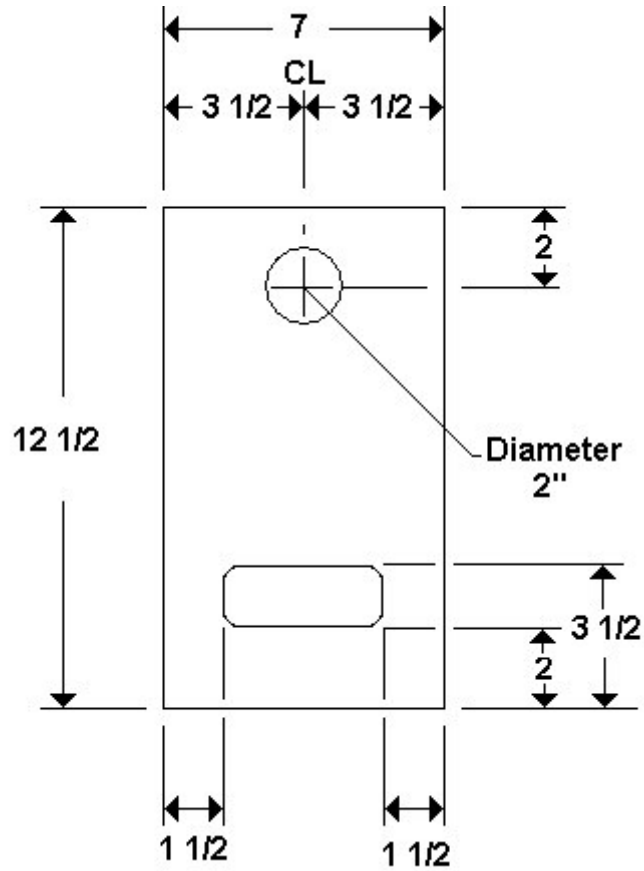

Fascia:

This panel may be either 1 1/4" MDF or 1 1/2" MDF. It may be constructed of a single layer, two layers of 3/4" material, or a layer of 3/4" and a layer of 1/2". If using two layers, the adhesive should be a hard glue such as Titebond.

When machining the woofer and tweeter countersinks, measure carefully to be absolutely certain they are the correct diameter. The diameter we specify is actually very slightly larger than the flange driver flange diameters, to account for the thickness of any paint or surface finish.

Woofer and tweeter mounting holes should be drilled at this point. There are five woofer mounting holes

The front edge of the fascia is rounded over with a minimum 3/8" radius, maximum 3/4" radius round over bit. If one chooses to veneer the front, roundover the side edges and leave the top and bottom square.

The inside edge of the woofer through hole should be flared with a 3/8" radius round over bit, sanded smooth and sealed with a thin layer of glue.

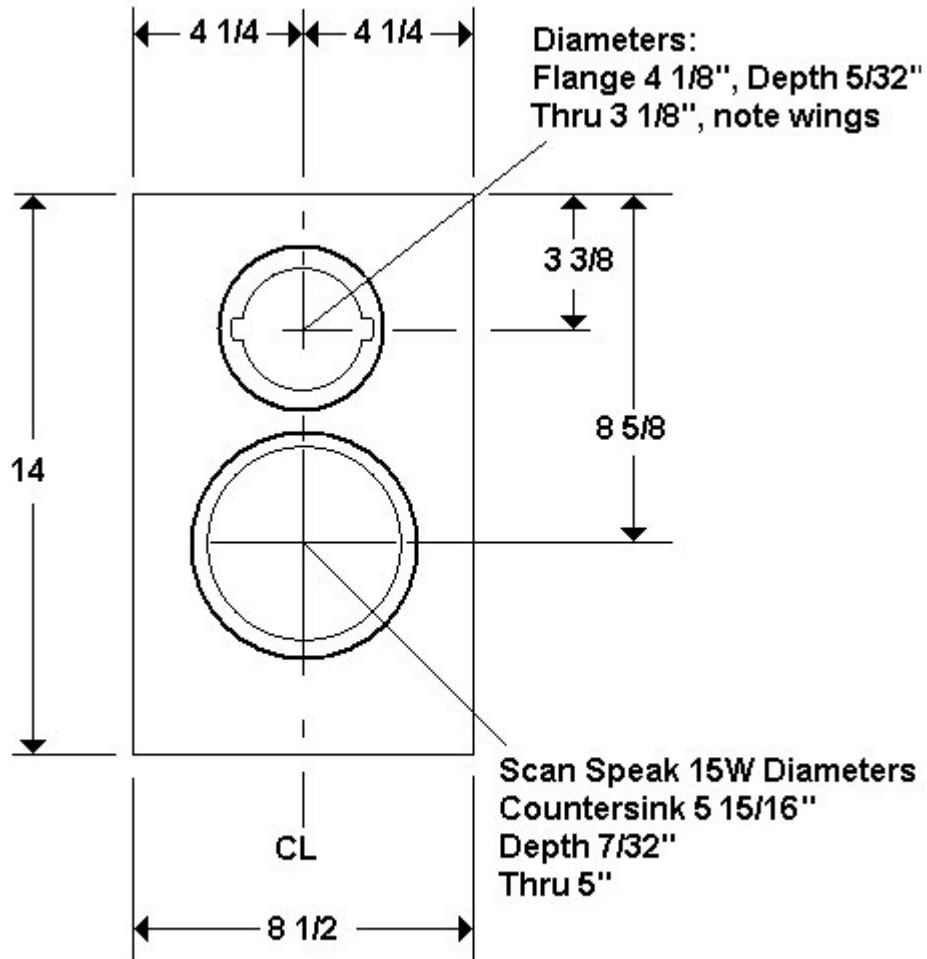

Inner Front:

This panel is machined from 3/4" plywood.

After machining, the inside edge of the woofer cut out should be flared by a 3/8" radius roundover bit . The roundover should then be sanded smooth. This leaves a very thin amount of plywood near the extreme left and right edges of the panel, so one must handle it with care during assembly.

Both the woofer and tweeter through holes should be sealed with a very thin layer of hard glue, to prevent any air leak due to the porosity of the plywood.

Note that these through hole diameters are larger than the matching holes in the Fascia. This is done to facilitate assembly and improve the aerodynamics behind the woofer.

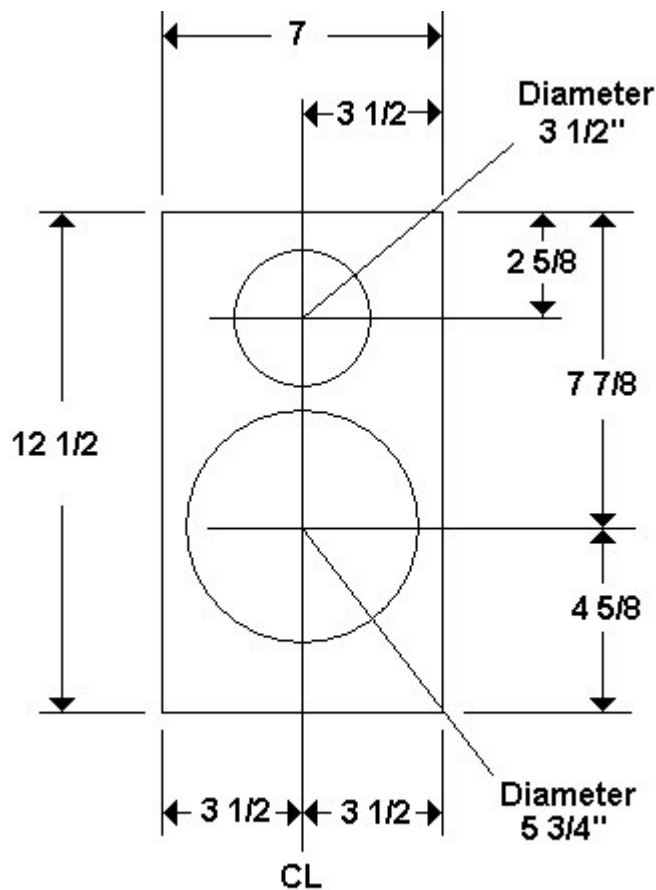

Assembly Order:

Label the side panels' inside top front corners, then mark the side brace positions. Remember opposite sides are mirror image! Glue on the side braces with Titebond. **Make sure to leave a 1" gap at the top edge so the top can be attached.** One can pin them with brads as well, then clamp them in a stack.

Meanwhile, lay up the backs using NCMS Soft Glue.

Using hard glue, assembly order is side + top + back; inner front; bottom; side; Top braces (pinch clamp). **Do not install the middle cross braces.**

Make "Glop" by mixing the remaining soft glue with pre-mixed drywall joint compound. Spread a layer of glop about 1/4" thick between the front and back brace in the area from the bottom edge of the woofer to the middle of the tweeter. Allow the glop to dry for a couple of days, then roll the cabinet to the opposite side and repeat the process. One can speed up the drying process considerably by aiming a fan into the cabinets; the glop will skin over, crack, then dry.

It is assumed the Fascia is finished separately and attached last.

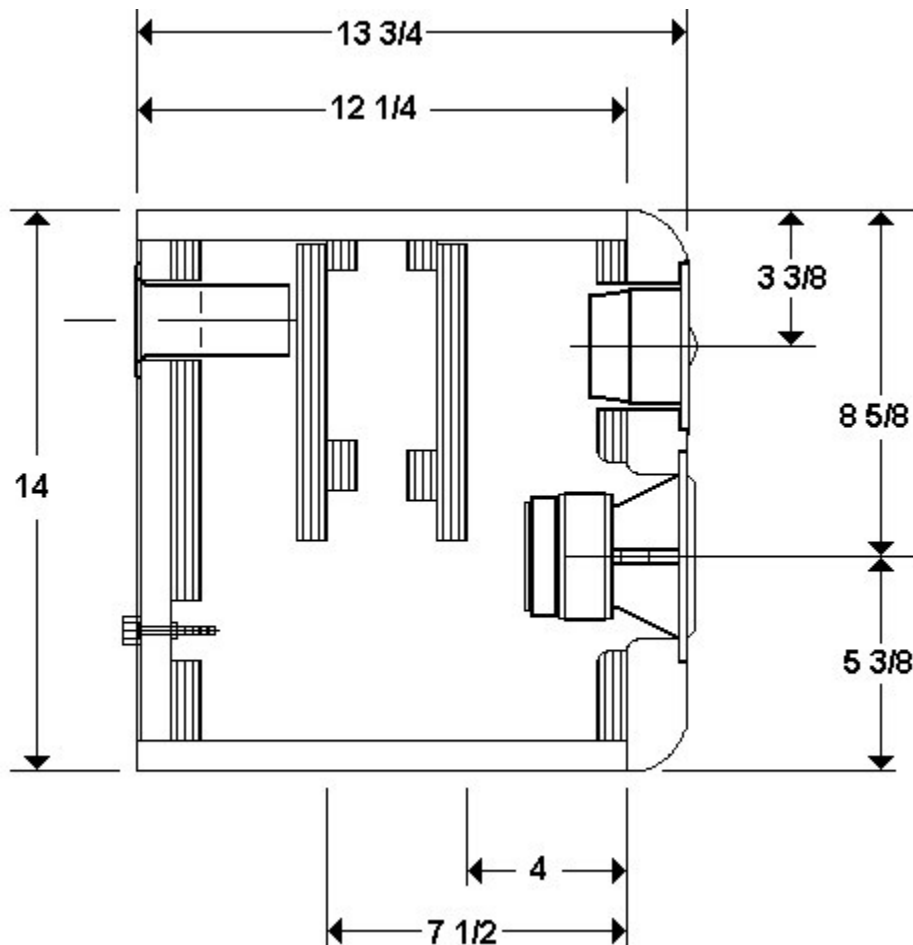

Binding Post and Crossover installation:

1) Attach the Big as Texas binding posts to the rear panel as follows:
Open the binding post hex heads completely with the hardware in order (see next paragraph), then insert the threaded sections into the mounting holes. Line up the large holes in the post horizontally, and with a T-Allen driver or long nail, go through the hole of the left post and through the hole in the right post. This will keep the binding posts from spinning while they are being tightened.

Outside is hex head, floating circle washer, knurled washer with knurls against the access panel cover;

Inside is Star washer, color coded nylon washer, nut.

Tightening the nut securely with a 5/16" (yellow) nut driver will draw the post tightly to the back panel.

2) The tweeter crossover is installed through the woofer opening. The crossover is inserted inductor first, rotated behind the brace and glued to the back panel between the binding posts and the port tube with Liquid Nails. Let gravity hold the network there overnight while the glue cures.

3) The woofer board and large woofer inductor is then installed through the woofer cut out. With the cabinet on its back, slide the woofer inductor and board along the bottom of the cabinet. Liberally cover the bottom and back edge of the inductor and bottom of the woofer board with Liquid Nails. Slide it back into place, make sure no wires are caught under it, and roll the cabinet onto its bottom.

4) Install the two middle cross braces with pinch clamps.

5) Allow everything to dry overnight.

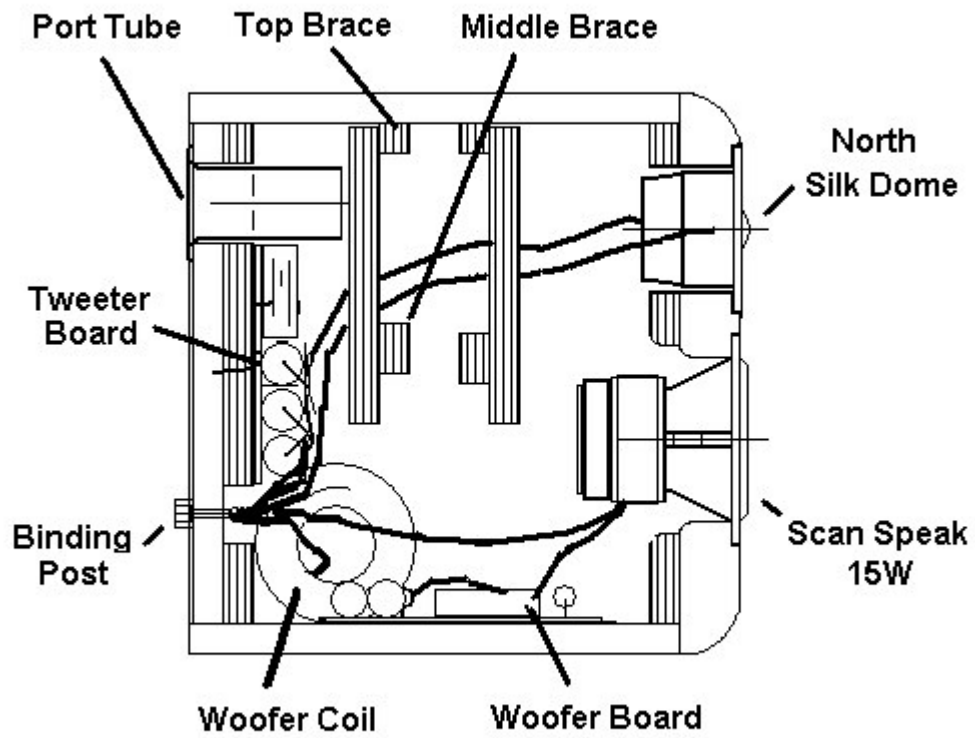

NORTH KITTY KAT ASSEMBLED LOUDSPEAKER SYSTEM

Final Assembly

1) Attach the crossover wires to the color coded posts red = woofer (+) and white = tweeter (+) to right Red Post; black = woofer (-) and blue = tweeter (-) to Black Post.

2) Dab a touch of red nail polish onto the outermost nuts to assure they will not come loose over time.

3) Cut the straws for the port tube (see below). The port tube is installed by thinly coating it with adhesive or hot melt just below the flange. Drop the port into place, cover the end with a small block of scrap wood, and give the block one good rap with a hammer to seat the port flush.

4) The cabinet is then returned to its back, the woofer and tweeter wires pulled through their respective driver openings. Cut the stuffing in sixths. Cut a slit about half way down the first piece, and push it behind the first brace such that the slit end goes around the port tube but does not block the end of the port tube. Do the same with the next piece, keeping it away from the end of the port tube as well. The last piece goes between the braces and cabinet front such that the woofer motor will push it in when the woofer is installed.

5) The white (+) and blue (-) leads are attached to the tweeter, red (+) and black (-) to the woofer. If the quick connects are loose, the way to tighten them is to pinch them back by the solder joint to the wire with needle nose pliers. Be very careful not to pinch the open end that goes onto the drivers. Then, as the quick connect is slid onto the driver lead it will get tighter and tighter as one pushes on.

6) Using the 1" black screws, install the drivers.

Optimum placement is on a 24" to 30" stand. **The rear of the cabinet must be within three inches of a wall to sound its best.**

Optimum listening axis is on to just above tweeter axis.

Port Optimization

North Creek Loudspeaker Kits can be tuned over about an octave by adjusting the length of straws inside the port tube. The straws should be cut before the port tube is installed.

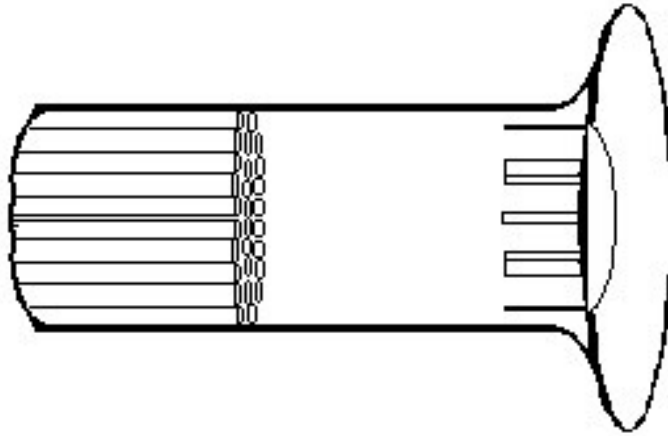

- 1) Insert the straws into the end of the tube with about 4" sticking out the back. The fit should be so tight that the straws begin to go out of round (65 straws for a 2" port, 125 straws for a 3" port). Wrap the end in tape, then pull out the bundle of straws and push the taped end into the port, again such that about 2" sticks out the back. Wrap this end in tape as well.
- 2) Remove the straw bundle and cut each end into a 5" length.
- 3) Slide the 5" straw bundle into the port such that they end just as the flare begins. One can adjust the length of straws emerging into the cabinet from the port to lower the tuning frequency by ear. We have found the optimum to be between flush and 3" sticking into the cabinet.

For those that are curious about the origin of this procedure, to the best of my knowledge it was first discussed in writing by Neville Theile himself. The earliest reference I know of was in an article by Dr. Theile in an ASA journal from the mid '60's, on non-linear port behavior. Which article and year it was precisely is now unknown to me. -GS

This publication is copyright © May 2006. All rights reserved.

North Creek Music Systems

PO Box 1120
Old Forge NY 13420

www.NorthCreekMusic.com