

North Creek

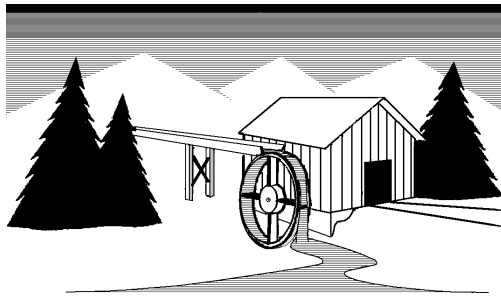

Music Systems

Prometheus

Loudspeaker Kit

**High Performance Loudspeaker System featuring
dual SEAS W18E001 Woofers and
Aurum Cantus G1 and G2is Ribbon Tweeters
in a QB3 Vented Enclosure**

Revised July 10, 2006

North Creek Music Systems

Prometheus Contents

The woodworker's kit portion of this loudspeaker system was shipped in two cartons.

Carton #1 contains:

- (1) Instruction Package.
 - Response Curves
 - The North Creek Cabinet Handbook
 - The North Creek Wiring Guide

- (1) Tube of "Liquid Nails" adhesive.
- (3) Quarts of NCMS Soft Glue (USA only).
- (2) 3" Port tubes.
- (1) 250 Black Straws.
- (4) Plastic Bags for Sand

- (2) Rolls of gasket tape.
- (50) #6-1" pan head black screws.
- (50) #6- 1 5/8" flat head black screws.
- (8) #10 X 3 1/2" deck screws
- (2) Sets of 4 Big as Texas Binding Posts
- (8) extra Texas Binding Post Nuts
- (1) Set of Big Toe Spikes.
- (1) Set of Very Big Toe Spikes.

- (2) Woofer Crossovers.
- (2) Tweeter Crossovers

Carton #2 contains:

- (2) Aurum Cantus G1 Ribbons.
- (2) Aurum Cantus G2si Ribbons.
- (4) SEAS W18E001 Woofers. (shielded EX for HO/T version)
- (4) 6 oz. Rolls of Dacron stuffing.

You will need to purchase:

- (1) One-Gallon tub of dry-wall compound.
- This item should be available at your local garden shop.

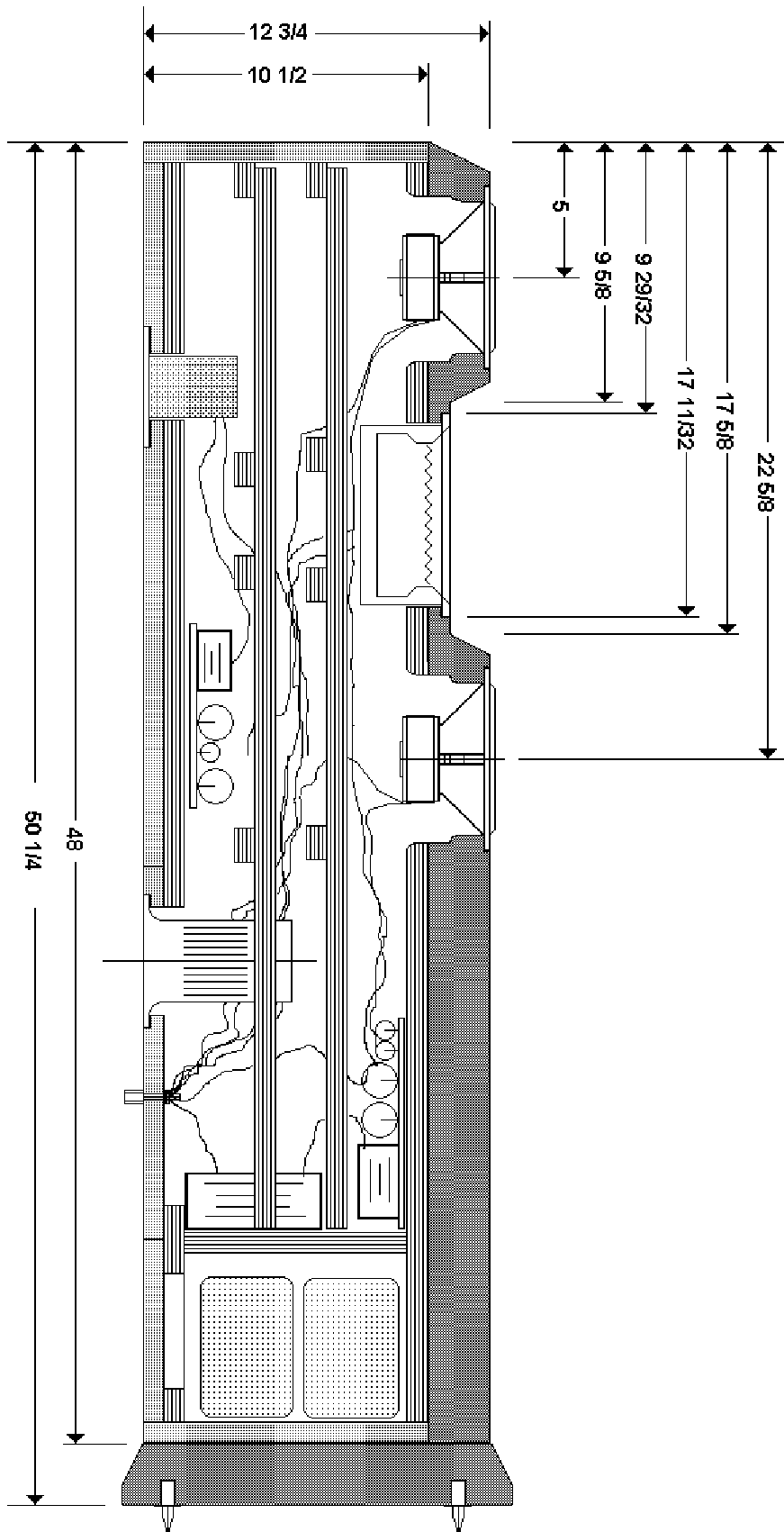

North Prometheus Loudspeaker System

The North Prometheus is a cost-no-object, reference quality ribbon hybrid loudspeaker kit.

The Prometheus cabinet is composed of three sections: The main body, the plinth, and the fascia.

The main body is a straight forward rectangular box, and does not require any special tools or finishing techniques. The only caveat is that for a cabinet this large, there is with a table saw that is anything less than perfectly square there is considerable tolerance build up. The best place for this tolerance build up to occur is at the bottom of the cabinet, since both the inner front and inner back are concealed by the fascia and lower back access panel, respectively.

The main cabinet should be finished independently of the fascia and plinth.

The fascia and plinth require considerably more machining, and this is where one really needs both good tools and good technique to get a great finish.

The #1 issue is telegraphing of the glue joints. The plinth and sections of the fascia are 2 1/4" deep, composed of three layers of 3/4" MDF. MDF seams do tend to telegraph over time, simply because MDF does have moisture absorption abilities.

For the plinth, what seems to work best is a thorough sizing with a thinned hard glue such as Titebond, followed by sanding and several layers of thinned shellac-based primer (such as Zinsser), sanded and repeated. This builds up a thick enough prime layer that the telegraphing is kept to a minimum.

For the fascia, the telegraph issue takes place along the seams where the front fascia sections (that hold the woofers) are adhered to the inner fascia section (which holds the G1 ribbon). The best solution I have found here is to deliberately make the seam visible by machining a slight "step" along the edges of the upper and lower front fascia sections, so they do not match up exactly to the 30 degree angle of the inner fascia section. Those with more skill may attempt a solid edge along the entire fascia edge of the Prometheus cabinet.

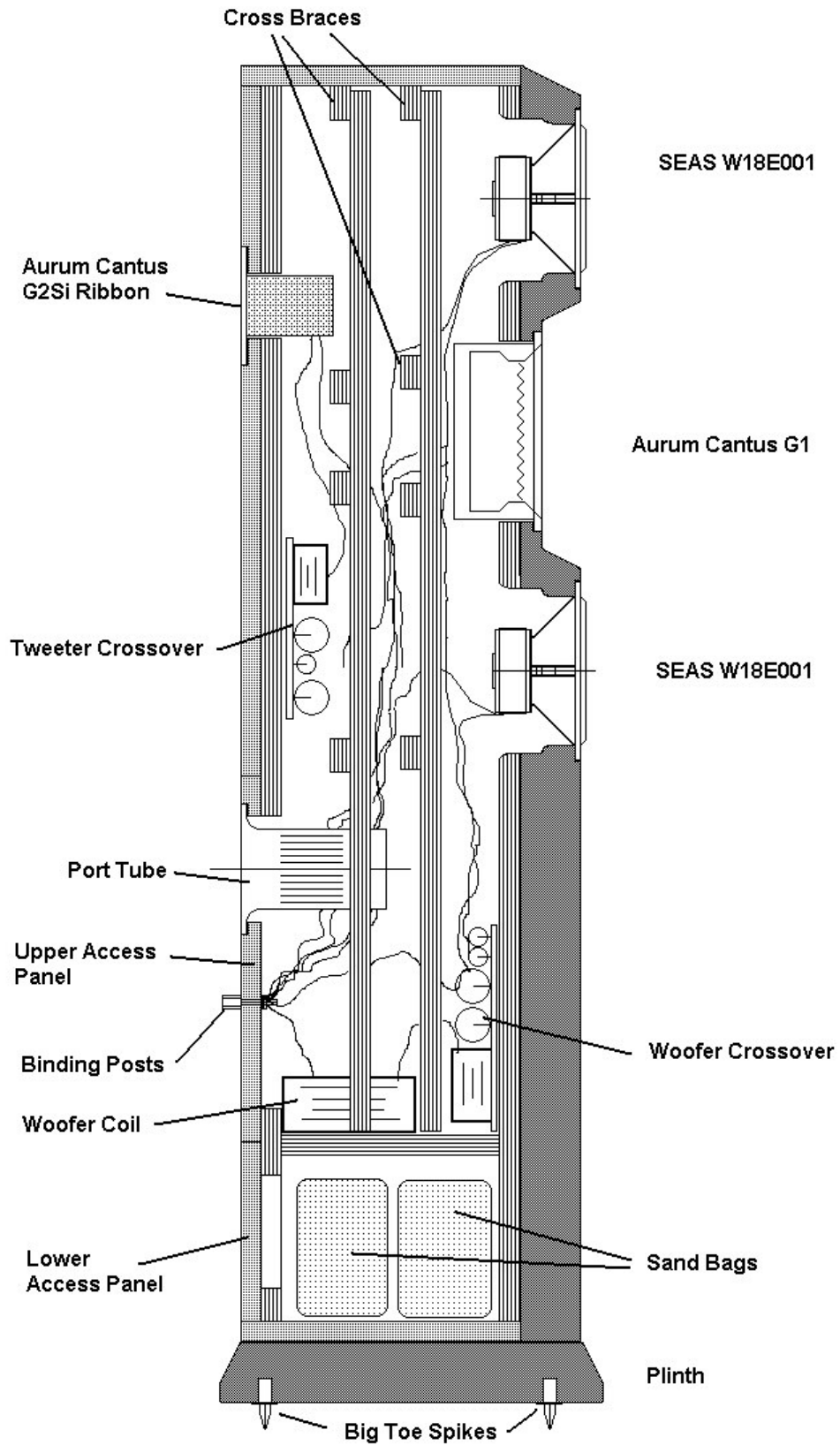

North Creek Music Systems

Prometheus Loudspeaker Cabinet

This publication is copyright July 10, 2006 by North Creek Music Systems. The cabinet design is the intellectual property of North Creek Music Systems. All rights reserved.

Sides

4 Pieces

3/4" MDF (may be pre-veneered)

10 1/2 x 48

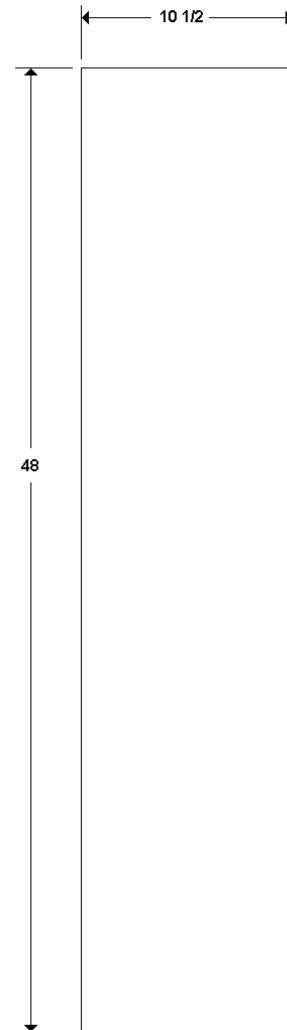

Top/Bottom

3/4" MDF

10 1/2 x 8 1/2

4 Pieces

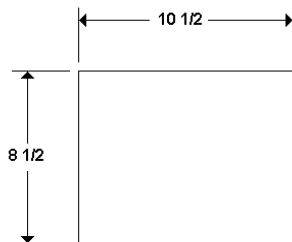

Outside Upper Back

3/4" MDF

8 1/2 x 26

2 Pieces

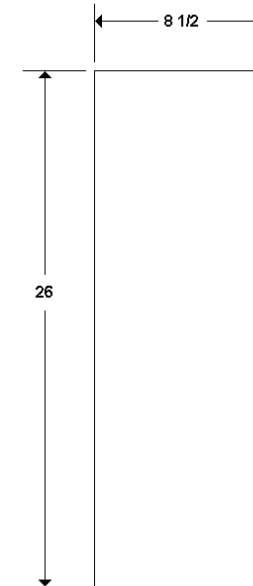

Outside Middle and Lower Back (Rear Covers)

3/4" MDF

8 3/8 x 13 5/8

8 3/8 x 6 3/4

2 Pieces each

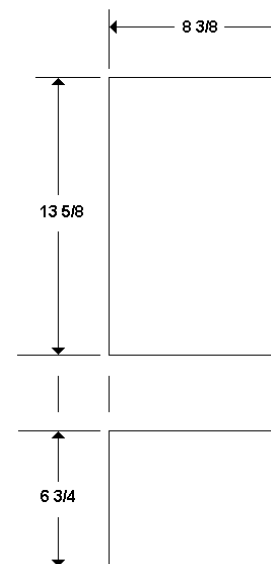

Inner Fascia

3/4" MDF

10x48

2 pieces

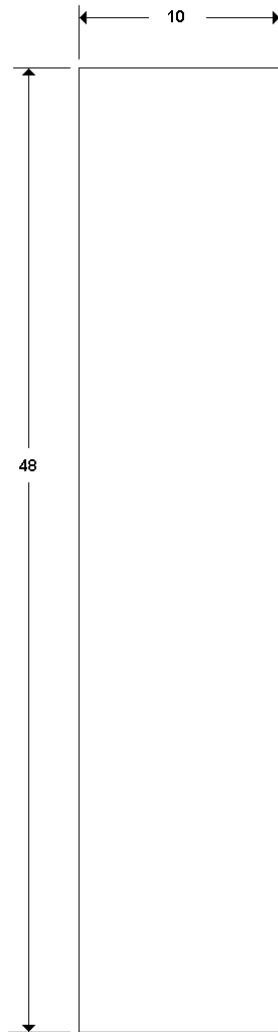

Inner Front, Inner Back

3/4" Plywood

8 1/2 x 46 1/2

4 pieces

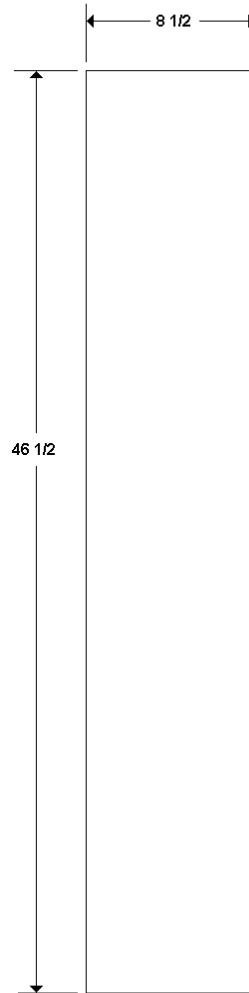

Shelf

3/4" MDF or plywood

8 1/4 x 8 1/2

2 Pieces

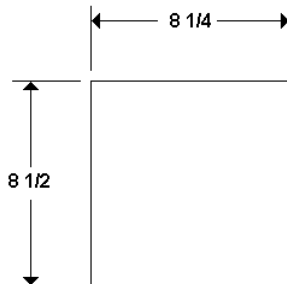

Brace Detail

1/2" to 3/4" Plywood.

Long brace is 1 1/4 x 39 1/4, 8 pieces

Cross braces are 1 1/4 x 8 1/4, 20 pieces

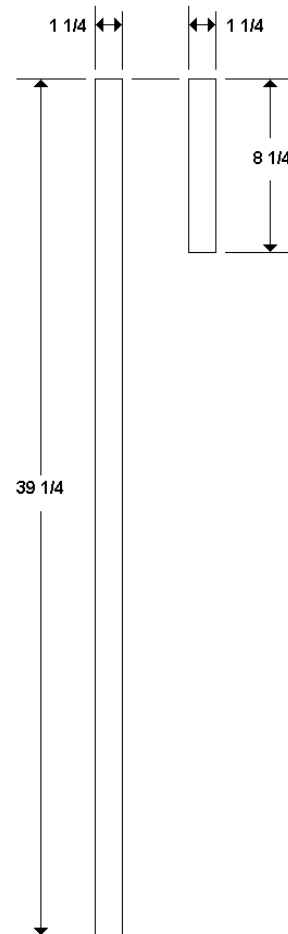

Plinth and Plinth Detail

2 1/4" MDF, 14 1/4" x 14 1/2"

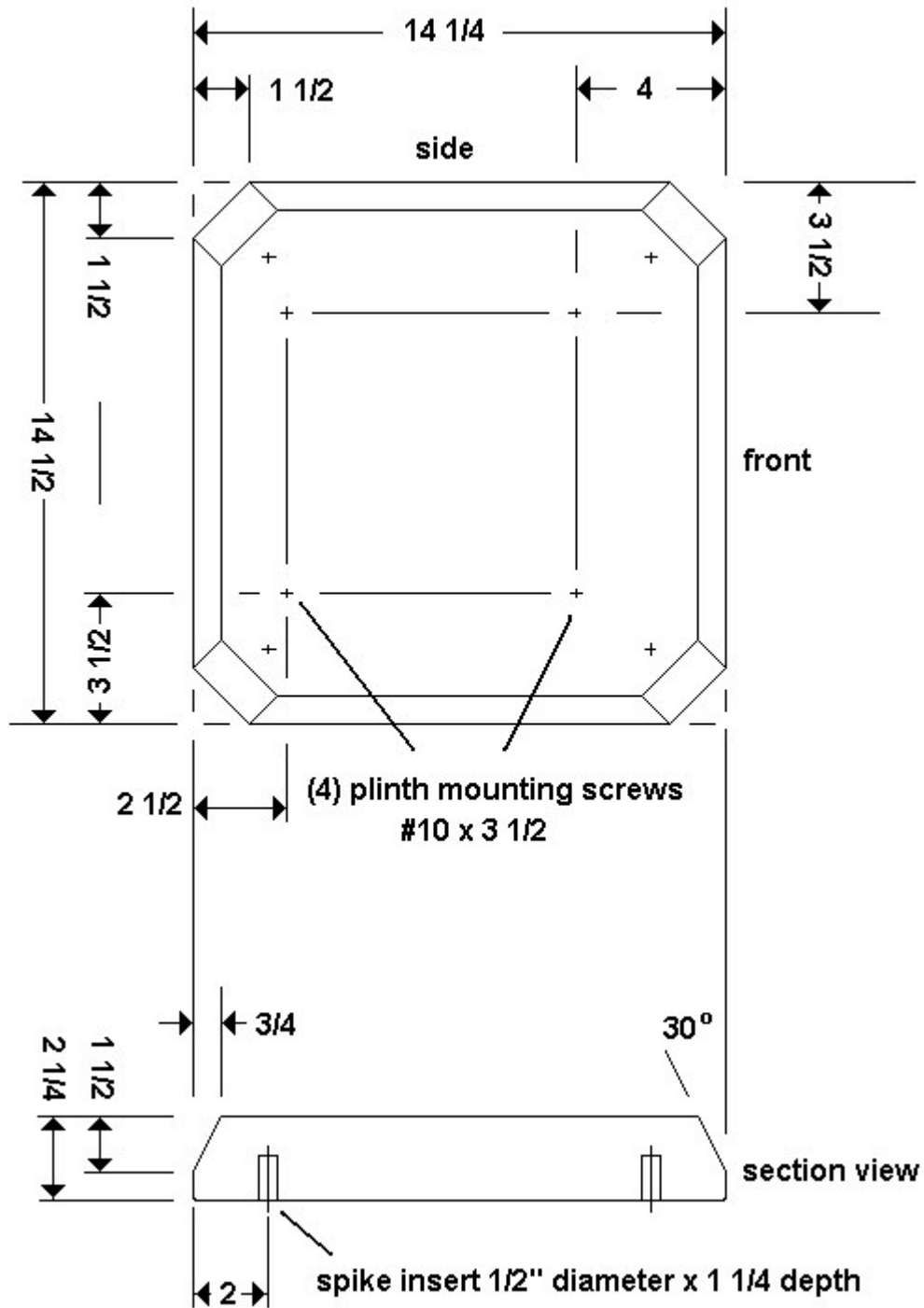

Inner Fascia Detail

Fascia: Material is 3/4" MDF, 10 x 48
SEAS W18E through 6 1/2"
Aurum Cantus G1 see G1 detail.

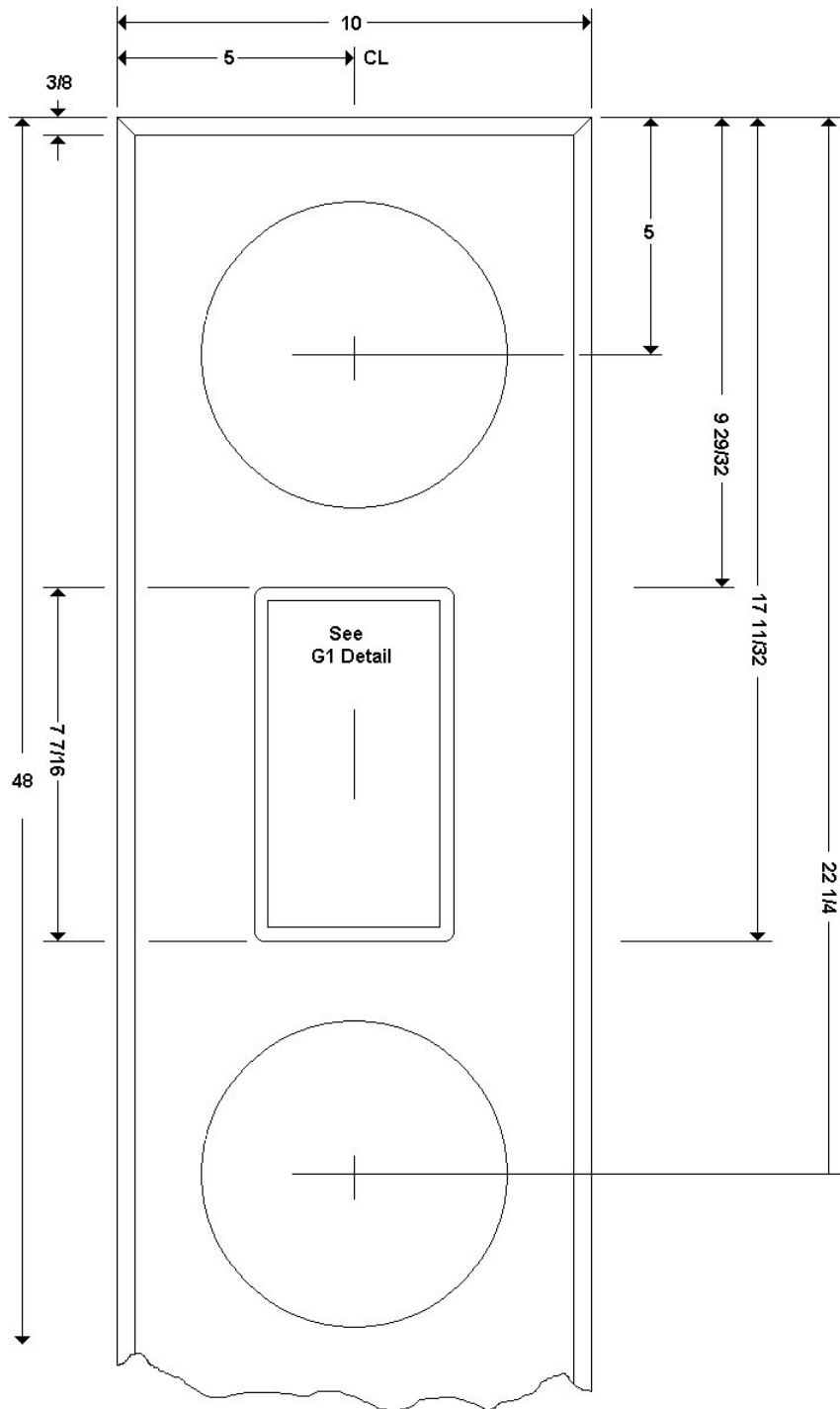

Aurum Cantus G1 Detail

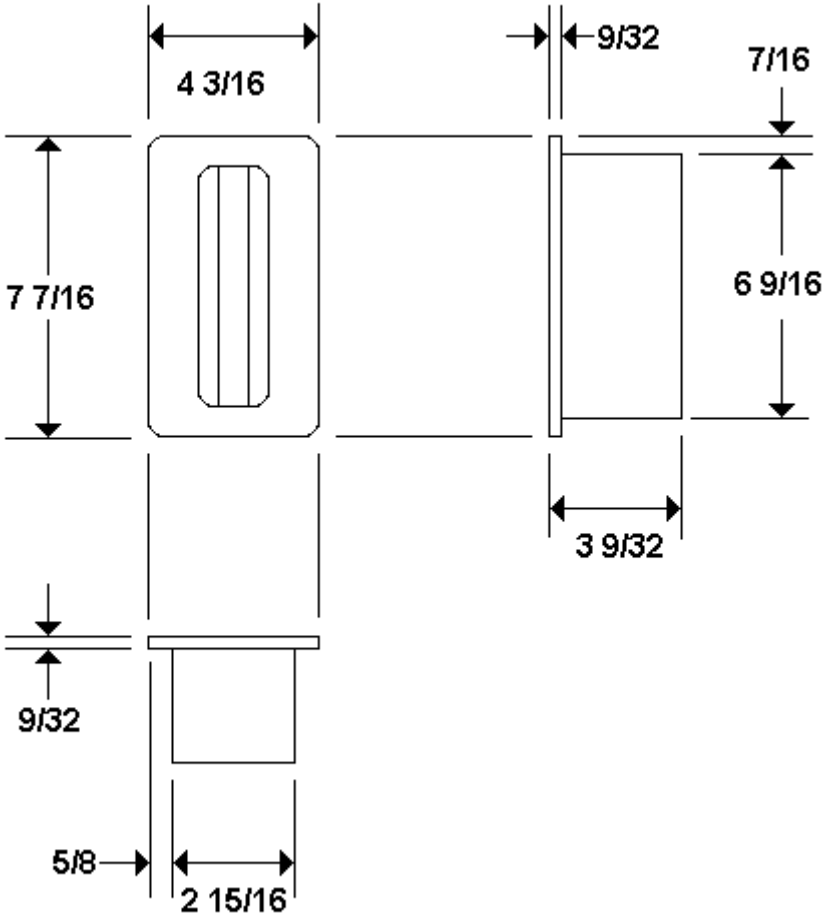

Upper Outer Fascia and Detail:

Material 1/5" MDF, 9 1/4 x 9 1/4

Edges are 30°

SEAS W18E001 Cut Outs:

Flange Countersink 7"

Depth 13/64"

Through 5 3/4"

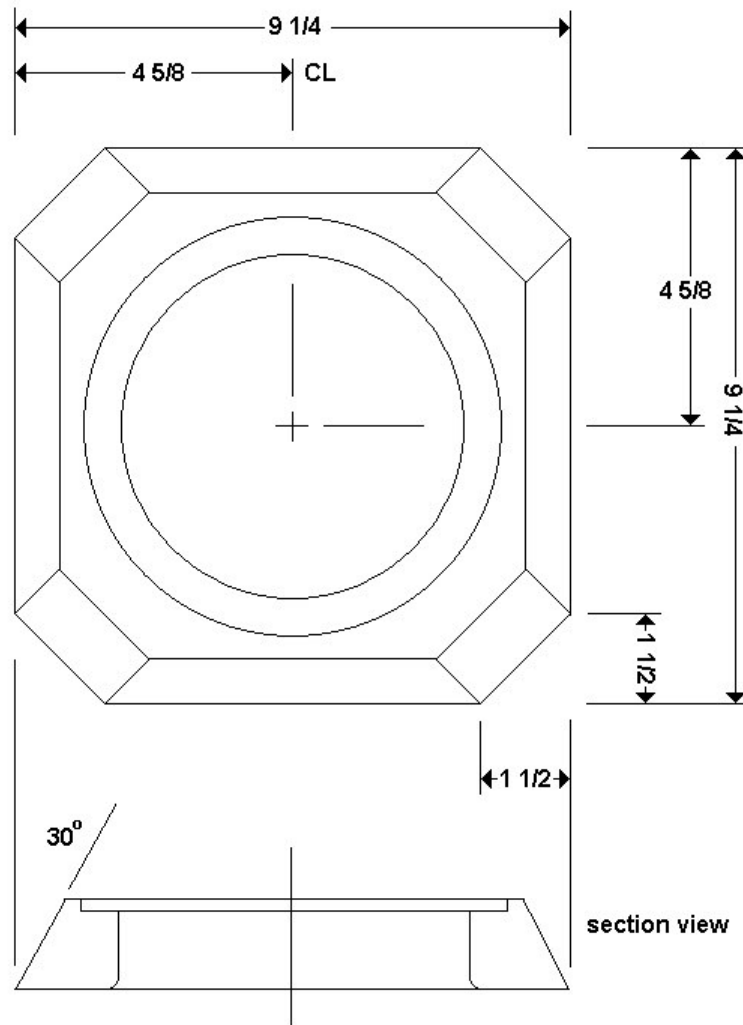

Lower Outer Fascia
Material 1/5" MDF, 9 1/4 x 30 3/8
Edges are 30°

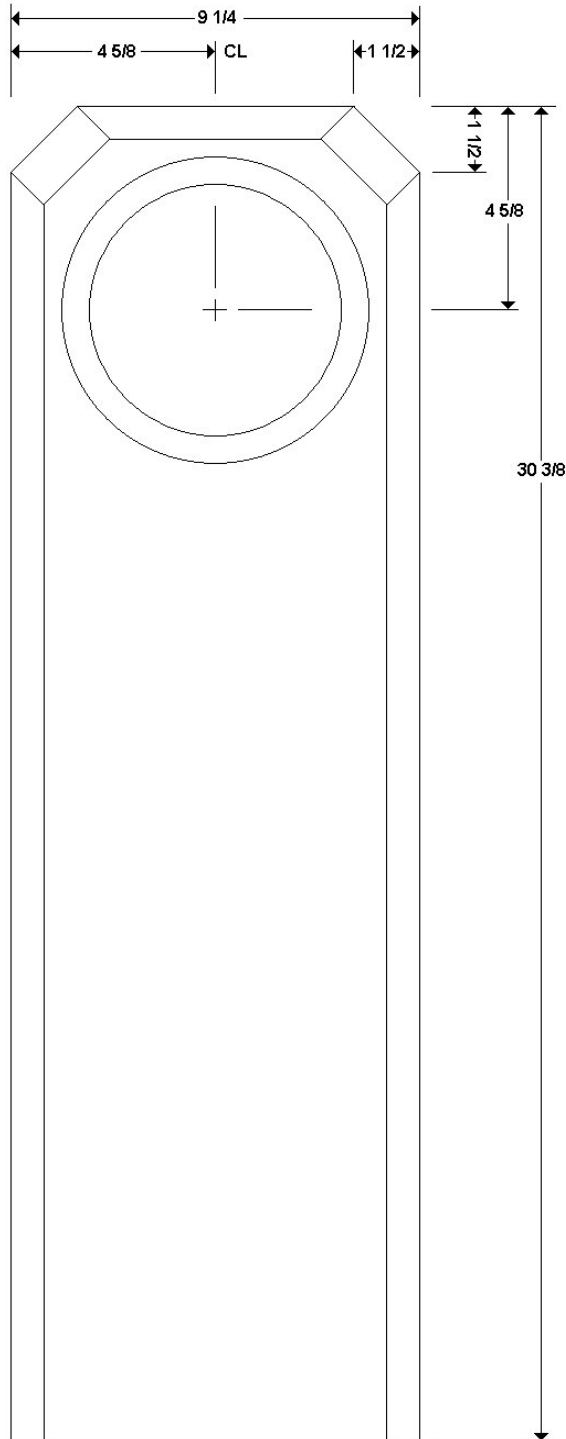

Fascia Lay Up Detail

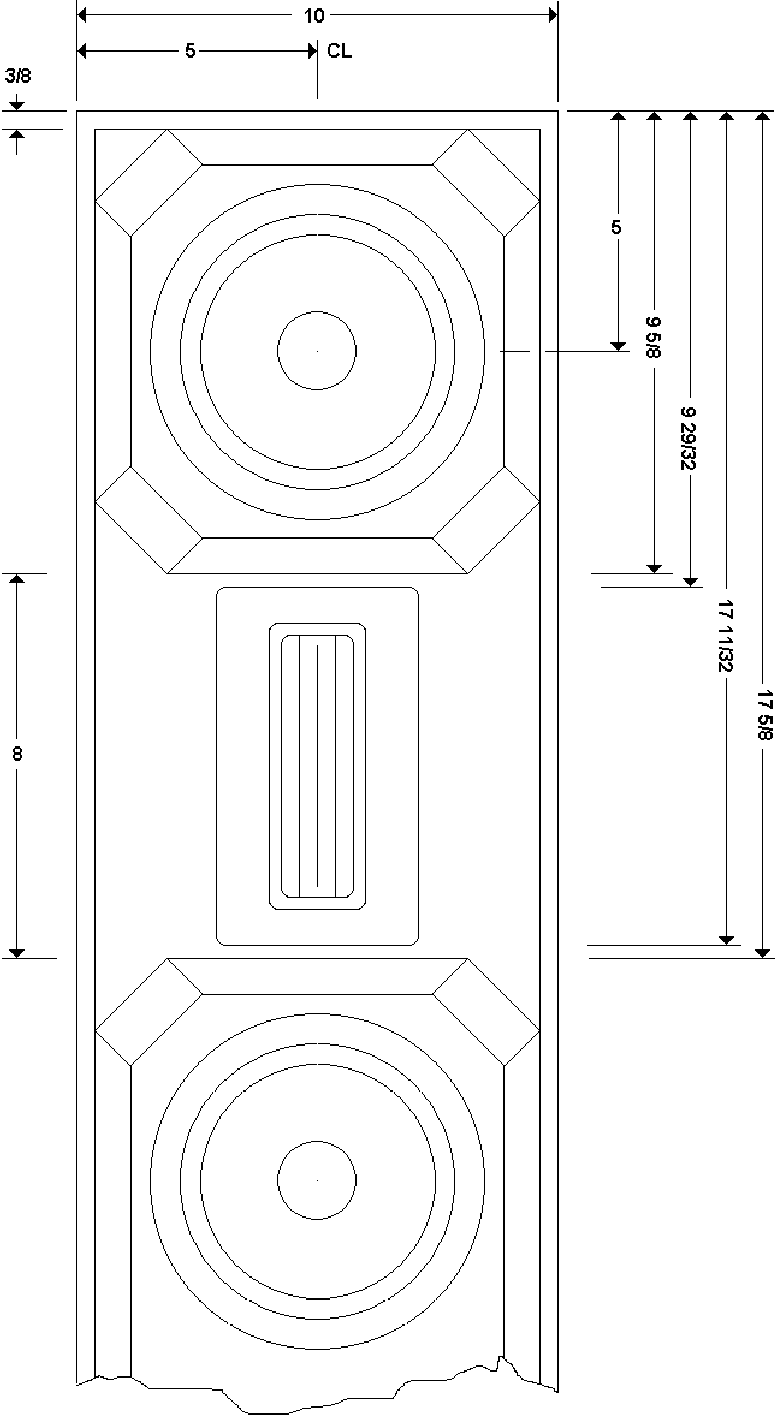

Inner Front Detail

Material is 3/4" plywood

SEAS W18E001:
through diameter 6 1/2",
flared on the inside edge of
the cabinet. The flare bit
should be a quarter round
3/8" radius.

See the AC G1 detail for
dimensions. Cutting the AC
G1 though hole a little larger
than required will make it
easier to lay up to the
Fascia.

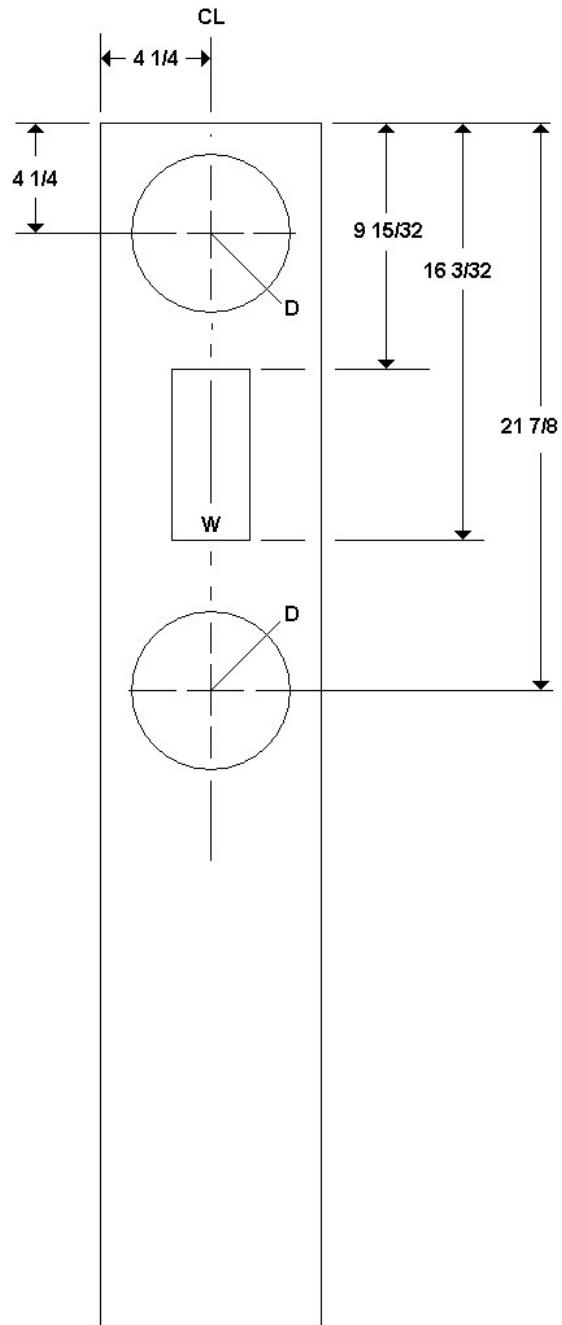

Inner Back Detail

Cut the G2si though hole a little larger than required to ease the fit when laminating to the inner back.

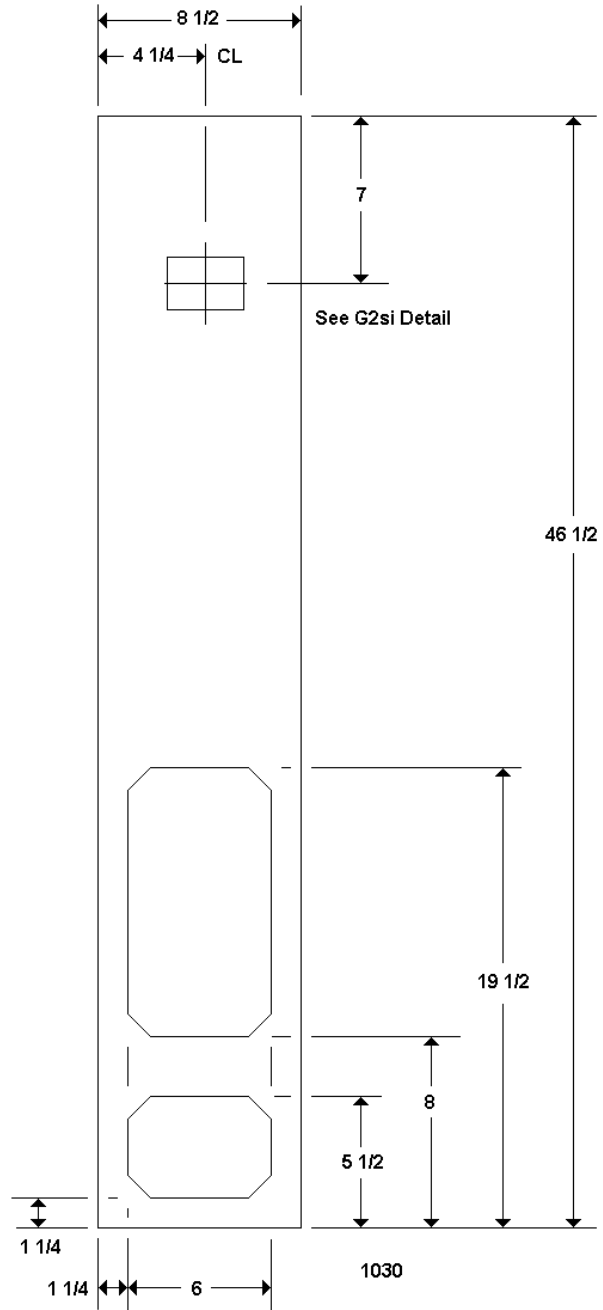

Aurum Cantus G2si Detail

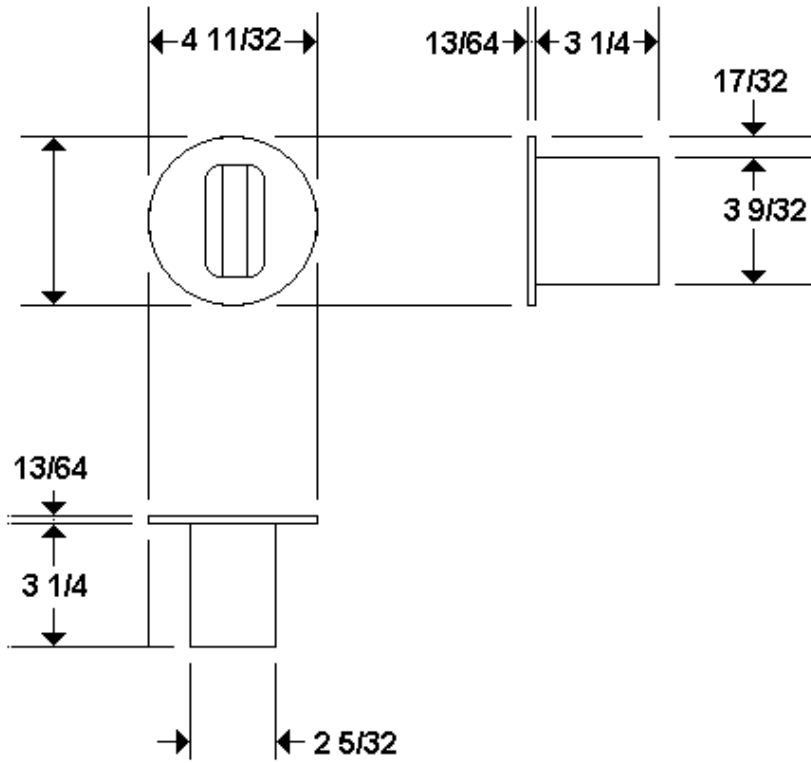

Outside upper Back Detail

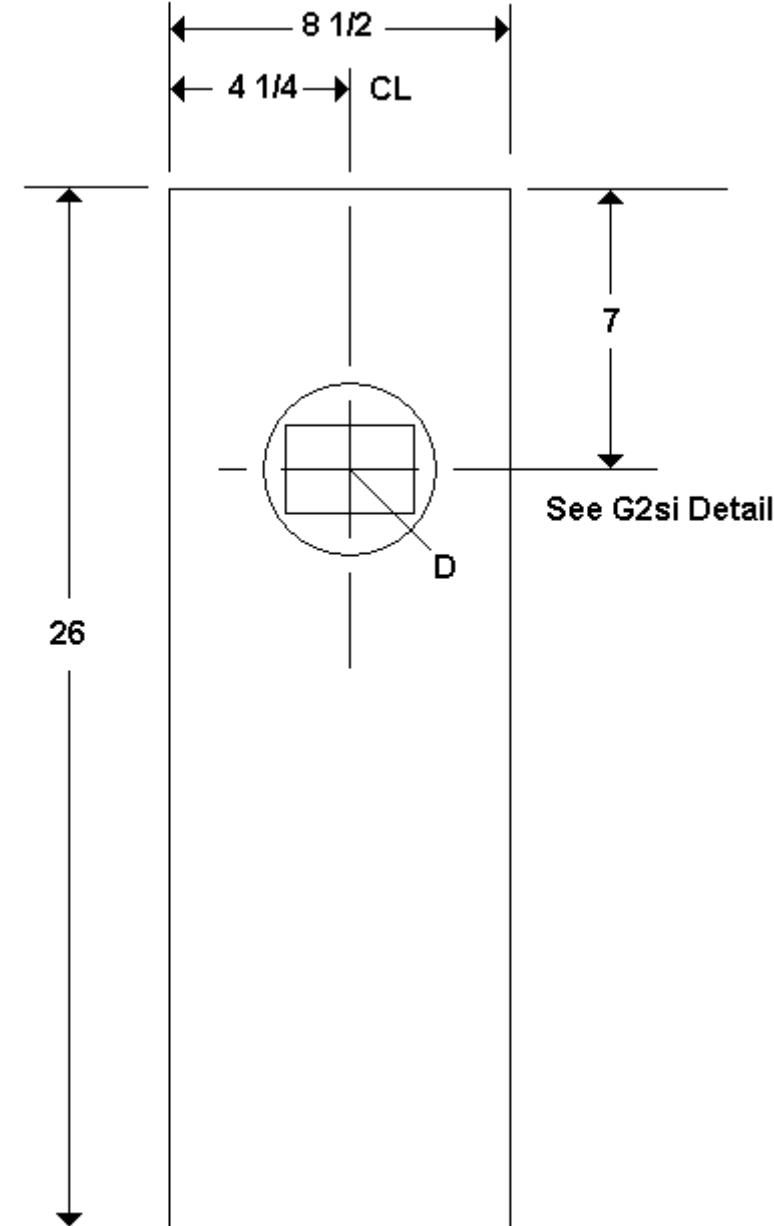

Middle Back (Upper Access Panel) Detail

The mounting holes are countersunk for the #6-1 5/8" drywall screws.

Texas Posts are 1/4", use two to single wire or four to bi-wire.

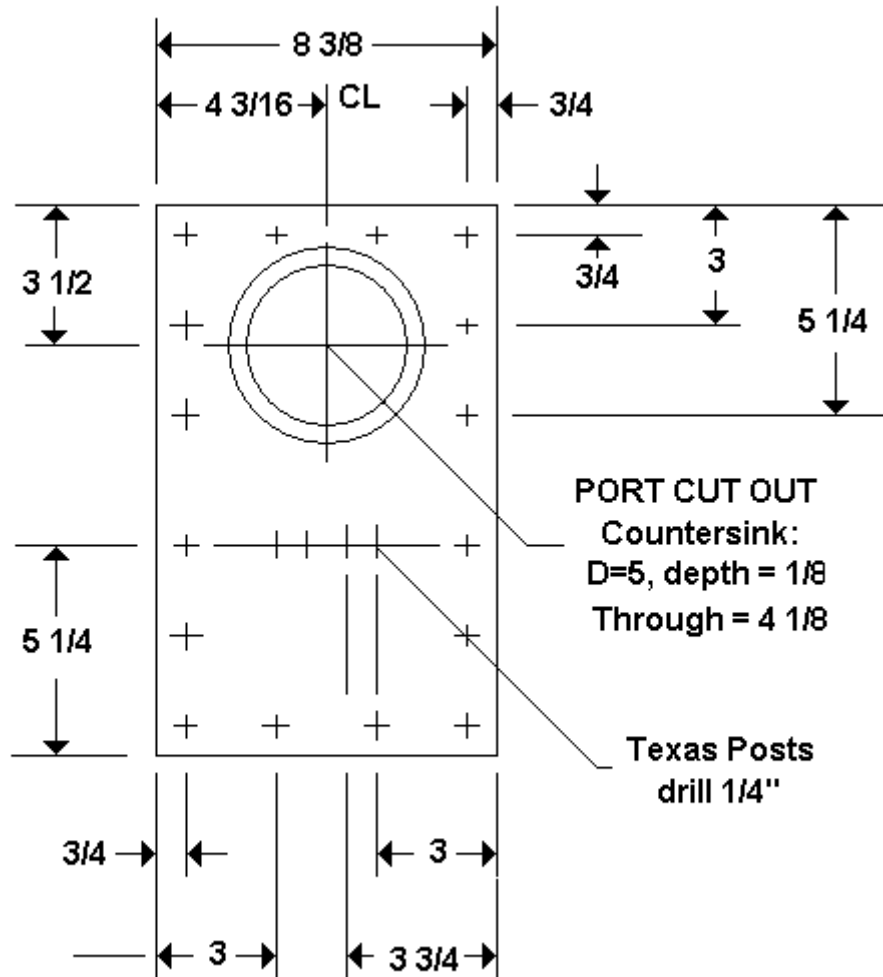

Lower Back (Lower Access Panels) Detail

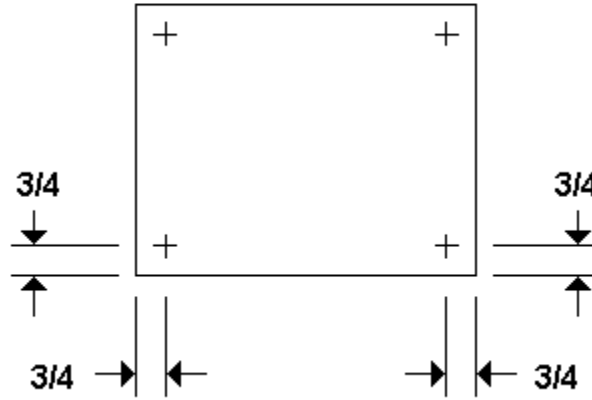

The mounting holes are countersunk for the #6-1 5/8" drywall screws.

Brace Positions

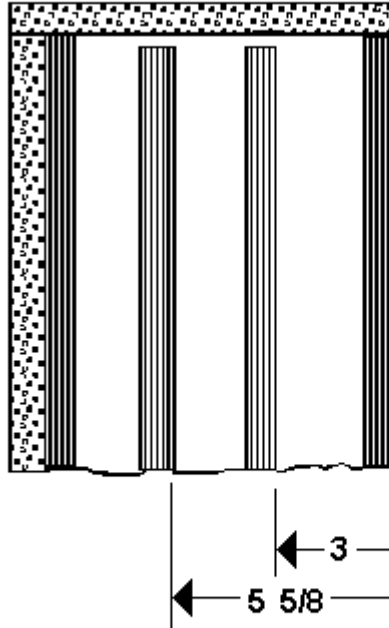

Note that the long braces fall just short of the top edge of the side walls (about 1/8" short). There is no need to get tighter as the cross braces will stiffen the cabinet top.

Cabinet Assembly

- 1) Pre-assemble all parts without glue to test the fit.
- 2) Mark "FRONT" and "TOP" directions (and use arrows) on the inside of all panels. Use a large black marker.
- 3) Mark the brace edge distances from the front of the cabinet on the inside sides of all panels.
- 4) Glue the long braces to the side wall. The easiest way to do this is to glue and pin the braces into position using 1.5" finish nails, then stack the four sides in two layers with the braces facing in each layer, then clamping the entire stack at once.
- 5) Lay up the inner back and upper back with soft glue. Allow everything to dry.
- 6) Begin the assembly gluing process, starting with side/top/back. Break several hours between steps to allow the glue to dry. (Or use the "two drill method" outlined in the Cabinet Handbook.)
- 7) Gluing order is side/top/back, test fit the shelf brace and trim slightly as required to get a perfect fit to the inner front, then glue into place. Then comes inner front. bottom, side.
- 8) Attach the cross braces with pinch clamps. Do not attach the cross braces behind the lower woofer hole yet (they will interfere with the tweeter crossover board) For the top cross brace, the key to getting a tight fit against the top is to pinch-clamp the back cross brace into place, then run stock through the G1 cut out and use a bar clamp from the stock to the cabinet top to wedge the cross brace against the top.

Make sure the lower cross braces do not interfere with the port tube.

Advice

When pre-assembling, take your time to make sure the panels fit together perfectly. This usually means rotating and revolving panels until a set is reached that works just right. Label each panel carefully on the inside with a large black marker to assure the sets do not get mixed up during assembly.

Use a lot of glue. It's much easier to get the glue between the panels before they are glued together.

Take your time, and make sure each panel is lined up perfectly.

Remember, when clamped, panels tend to "flow" to relieve the pressure.

Glop Coating

This kit should include three quarts of NCMS Soft Glue. Roughly 2 1/2 quarts of pre-mixed drywall joint compound is also required. It is easiest to add the glop before the fascia is installed and convenient to do so during the same time the fascia is being finished.

1) In a large container, make glop by mixing 1 1/4 quarts of the soft glue and 1 1/4 quart of drywall compound. A wooden spoon, large wire whisk or drill-driven paint mixer works well. If the mixture becomes too thick, add a maximum of 1/4 cup of water. Mix the glop about twice as long as you feel you need to; uniformity is the key. It should take about 5 minutes.

2) With the cabinet on its side, scoop the glop onto the cabinet side wall and press it on with your fingers or a small piece of cardboard. The glop is most effective away from the cabinet corners, so there is no need to twist and turn to cover the entire wall. There is no need for glop in the sand chamber.

3) Allow a minimum of 48 hours for the glop to set. One can speed up this process considerably by aiming a fan into the cabinet. The glop will skin a crack, then dry.

4) Rotate the cabinet and repeat step (2).

Advice

It is often easier to pile the glop between the braces by the handful, then spread it with your fingers or a very thin piece of cardboard. The mixture is non-toxic and washes off with water.

Uniform coverage of the panel with glop is not required. Since glop has no effect near the cabinet corners, it is not necessary to go to extremes to coat them.

Fascia Finishing:

Please see the comments at the beginning of this manual concerning the fascia finishing. With material this thick made of so many lamination, telegraphing is an issue. For a smooth black finish, many coats of priming and sanding is the key. This works well:

- 1) Size all edges with a sizing made of Titebond wood glue thinned with 2 parts water. Let dry.
- 2) Fill any scratches with drywall compound or wood filler and let dry.
- 3) Sand smooth to 220 grit.
- 4) Lay up the fascia as shown in the Fascia Lay Up Detail.

- 5) Prime all angled edges with a thinned shellac-based primer such as Zinsser.
- 6) After several hours or overnight, sand the angled edges smooth, then re-prime.
- 7) Allow the fascia to dry overnight, then sand. Check for telegraphing lines, prime and sand as needed.
- 8) Prime the entire fascia via spray.
- 9) Paint as necessary via spray.

Fascia Installation

The easiest way to do this is lay a sheet of MDF roughly the same size as the fascia on two saw horse, make sure it is dust free, and cover it with heavy plastic wrap. Make sure there are wrinkles in the wrap. The main cabinet is then attached to the fascia as follows:

- 1) Coat the fascia NCMS Soft Glue. Take special care leave a very very thin layer beside the woofer cut outs. Too much and there will be squeeze out; too little and there will not be a seal.
- 2) Carefully clamp the cabinet to the fascia. Immediately wipe up any squeezed out glue with a damp rag. Allow to dry overnight.

Plinth Attachment

The plinth should be lined up to mate with the front edge of the fascia. Attach the plinth with the 3 1/2" #10 screws.

Tweeter Crossover Installation

- 1) With the loudspeaker cabinet lying on its back, place the tweeter crossover on the cabinet back behind the lower woofer hole.
- 2) Feed the individual white, blue, yellow, and green wires along the front of the cabinet as high as possible. Feed the long White and Yellow wires marked "POST" and multiple Blue/Green wires down towards the binding post cover.
- 3) Move the tweeter crossover out of the way and apply several large beads of Liquid Nails adhesive or clear silicone to the cabinet rear.
- 4) Place the tweeter crossover into position and press to distribute the adhesive.
- 5) Attach the cross braces with pinch clamps. One can install the cross braces in such a fashion that they press on the tweeter crossover board, holding it in place. Allow to dry overnight.

Woofers Crossover Installation

- 1) Check the make sure the tweeter board glue has dried.
- 2) With the cabinet on its front, insert the woofer crossover board through the opening in the rear panel about 1/4" above the cabinet bottom. Push the long Red and Back woofer wires up towards the woofer cut out.
- 3) Move the crossover board and apply several beads of adhesive to the inside front of the cabinet. Press the woofer crossover board in place. Install a cross brace such that it presses onto a section of the woofer crossover, to hold it in place. Allow to dry for several hours or overnight.
- 4) With the cabinet standing up, apply several beads of adhesive through the rear opening to the base, sidewall and back in one corner of the cabinet. The object here is to apply enough adhesive that the large woofer inductor is heavily glued on two sides and the bottom. Put the large woofer inductor in place. Attach a cross brace to hold the woofer inductor in place. Allow to dry.
- 5) Apply the gasket tape to the inner back .
- 6) Attach the Texas Posts™ to the rear access panel covers. The connector order is:
From the outside: Hex Head, Slip Ring, Knurled Lock Ring.
From the inside: Star Washer, Nylon Seal Washer, Nut.
One can open the hex head all the way and slide a long, thin nail or screwdriver though the shaft hole, then tighten the nut from the inside with a 5/16" nut driver (yellow handle).
- 7) Attach the crossover internal wiring to the binding posts as follows:
Long Blues/Greens (tweeter networks ground) to left-most black post.
Long White/Yellow wires with white shrink tube (tweeter networks + input) to left-most red post.
Blacks (woofer network ground) to right-most black post (the violet wire is for the impedance compensation twister ground).
Coil lead (woofer network + input) and red lead (twister + input) to red-most red post.
Dab paint or nail polish on the threads to prevent the nuts form loosening.
- 8) Attach the rear covers to the cabinets with the 1 5/8" drywall screws.

Port Installation

Please see the special section below on port optimization.

- 1) Cut the drinking straws into 120 pieces of 5" each.
- 2) Insert into the port tube. The fit should be so tight that the straws just begin to go out of round, and can not be pulled out without effort.
- 3) Press the straws into the port tube, allowing 1" to project out of the back of the tube.
- 4) Drill four small holes on opposite edges of the port tube flange and into the cabinet rear.
- 5) Adhere gasket tape to the inside of the port tube countersink. Insert the port tube into the cut out, then screw the port tube flush.

Note: one can adjust the port tuning considerably by adjusting the straw length and position within the port; shorter straws raise the tuning frequency and output, increasing the amount of straw inside the port tube raises the tuning frequency while maintaining the output level. Experimentation is suggested after the system has broken in.

Once the optimum tuning is reached, one may permanently fix the straw positions by dipping the port tube and straws into a thin mix of black paint, soft glue and water. The port should then be glued into place with clear silicone.

Stuffing Installation

- 1) Place the cabinet on its back. Locate the white, blue, yellow and green wires. Extend these wires through the front tweeter cut-out.
- 2) Locate the red and black wires terminated with the .250" quick-connects. Extend these wires through the woofer cut-outs.
- 3) Cut the stuffing rolls in half the long ways. Install all of the stuffing into the cabinet, wedging between the braces and around the port tube. Make sure the stuffing goes all the way to the cabinet top and bottom. Make sure the region near the end of the port tube is unobstructed.

Rear Tweeter Installation

- 1) Attach the yellow wire to the Aurum Cantus G2si positive (marked with a red dot) and secure the nut.
- 2) Attach the green wire to the tweeter negative and secure the nut.
- 3) Dab paint or nail polish on the threads to prevent the nuts from loosening.
- 4) Position the tweeter with the flange lining up with the screw holes, and attach with the #6 black screws.

Front Tweeter Installation

- 1) Attach the white wire to the Aurum Cantus G1 tweeter positive (marked with a red dot) and secure the nut.
- 2) Attach the blue wire to the tweeter negative.
- 3) Dab paint or nail polish on the threads to prevent the nuts from loosening.
- 4) Position the tweeter with the flange lining up with the screw holes, and attach with the #6 black screws.

Woofers Installation

- 1) Adhere the gasket tape to the woofer countersinks, beginning at the top right screw hole so the screw hole is easy to find later.
- 2) Attach the red wire to the woofer positive (marked with a "+" or red dot).
- 3) Attach the black wire to the woofer negative (marked with a "-").

Note that if the quick connects give a loose fit, the only way to safely tighten them is to very slightly squish the area of the quick connect near the solder joint to the crossover wire. Then when sliding the quick connect onto the woofer terminal, the fit will get progressively tighter as one pushes farther. Eventually it will lock. To solder, use an 80 Watt iron and get in and out quickly.

- 4) Position the woofer frame to line up with the screw holes, and attach with the #6 Phillips head screws provided.

Placement

The Prometheus is capable of an extraordinary three dimensional presentation. However, improper placement in relation to room boundaries may emphasize room frequency response aberrations, while proper placement may eliminate them. Experimentation is mandatory.

Do not underestimate the importance of this procedure.

As a starting point, the face of the loudspeakers should be four feet from the back wall, six feet apart and slightly toed in. Move the loudspeakers around the room in one foot steps, then six inch steps, until the bass is tight and crisp. Then, adjust the toe in by quarter inch steps until the image focuses properly and the sound stage extends beyond the loudspeaker positions. Last, adjust the spikes by single turns until the image floats above and behind the speaker positions. When it locks in, you will know.

Spikes

This loudspeaker was designed with the Big Toe and Very Big Toe spikes. Use the Very Big Toes for the front spikes and the Big Toes for the rear spikes. The spikes should be adjusted such that they all pierce the carpet and tilt the cabinet back slightly. The lock nuts go on top of the spike above the plinth. The driver integration is smoothest when the listening axis is exactly the same as the front tweeter axis.

Sand Filling:

This loudspeaker comes supplied with four heavy plastic bags. Once final placement has been determined, these bags should be filled with sand and installed into the bottom chamber. Be careful not to cut the bags with the protruding tips of the plinth mounting screws.

Port Optimization

North Creek Loudspeaker Kits can be tuned over about an octave by adjusting the length of straws inside the port tube. The following facilitates port tube removal:

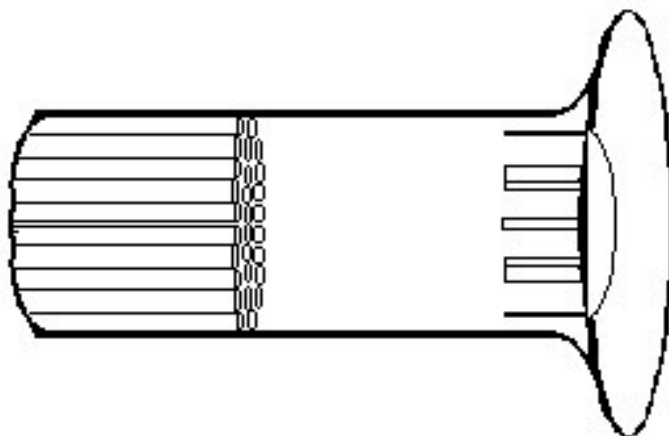

- 1) Drill four holes in the flange of the tube large enough to accept small screws.
- 2) Cut the straws into 5" lengths. Insert the straws into the end of the tube with one inch sticking out. The fit should be so tight that the straws begin to go out of round (65 straws for a 2" port, 125 straws for a 3" port).
- 3) Wrap the straw bunch sticking out of the port tube with tape. This secures the straws and makes it easy to adjust the length emerging from the port.
- 4) Install the port tube into the cabinet. The fit should be tight but the tube should still be removable with a little pulling.
- 5) Secure the port with screws.

One can adjust the length of straws emerging from the port to adjust the tuning frequency by ear. We have found the optimum to be between 1" and 2½".

Once the "perfect" tuning is reached, the port can be fixed by dipping the entire assembly in clear shellac or black paint.

For those that are curious about the origin of this procedure, to the best of my knowledge it was first discussed in writing by Dr. Neville Theile himself. The earliest reference I know of was in an article by Dr. Theile in an ASA journal from the mid '60's, on non-linear port behavior. Which article and year it was precisely is now unknown to me. -GS

Fine Tuning the North Creek Prometheus Loudspeaker System

There are five adjustments that can be made to "fine tune" the sound of the Prometheus loudspeaker system to match the sound of the room and associated equipment. These are as follows:

Rear Tweeter Level:

There are no resistors in the Prometheus Rear Tweeter signal path. This means that the tweeter is playing at full level (96dB), which at three feet reflection off the back wall is about 83 dB when it reaches the loudspeaker face. We have found this to optimum for a room with some treatment behind the loudspeaker. One can lower the rear tweeter output by adding a single resistor to the signal path by hardwiring it into the yellow lead.

High Frequency Level:

The Prometheus G1 Tweeter has a single resistor (bypassed by a capacitor) in the signal path, and a second resistor in parallel. To increase the G1 output, one must bypass the series resistor with a single 10.00 ohm North resistor. To decrease its output, one must bypass the parallel resistor with a North 10.00 Ohm resistor.

Low Frequency Balance:

The extreme low end output of the Prometheus loudspeaker is controlled by the length of straws in the port tube. There is a section in the manual regarding port tuning, but following is a brief description of what to expect:

A port tube with long straws will have very deep bass but at a reduced level. One can tune the Prometheus as low as 25 Hz, but the low end output will be greatly reduced and extremely overdamped.

A port tube with short straws (or no straws) will have a lot of output but higher in frequency. One can tune the port as high as 48 Hz, and the Prometheus will produce a whole lot of boom at that one frequency.

We target a tuning between 32 and 35 Hz. This is achieved by using 5" straws pushed through the port such that they stick out 1" beyond the end of the port tube and into the cabinet. This is the optimum "QB3" alignment.

One must note it is not carved in stone what tuning will be best for the room and equipment. The loudspeaker has the ability to be tuned anywhere in the octave between 25 and 50 Hz, which an output control of about 6dB.

Twister Presence:

The twister circuit is in parallel with the entire loudspeaker system, and functions only from 500 Hz to 2kHz, where it stabilizes the impedance. Most amplifiers sound better with the twister in place. However, one can experiment simply by unhooking thin red lead from the woofer binding post (this lead is 14 AWG with red insulation). To completely remove the Twister from the circuit, remove both the thin red wire with red shrink tube from the red binding post and the thin violet wire with black shrink tube from the black binding post.

This publication is copyright © July 2006 by North Creek Music Systems. All rights reserved.

Last revision July 12, 2006

North Creek Music Systems

PO Box 1120
Old Forge NY 13420

www.NorthCreekMusic.com